



**Technical Data &  
Selection Procedure**

# Ravistar **diffusers**



Continuous Slot, Linear,  
Multicone Ceiling, Circular,  
Perforated Face, Laminar Flow,  
Hi-Flo Jet, Adjustable Vane,  
Spot Diffusers/Jet Nozzles,  
Swirl, Exhaust Valves

# Contents

1.	Range of Diffusers and Selection Procedure .....	1
2.	Continuous Slot Diffusers - Model CS-F .....	3
3.	Linear Diffusers - Model DSL .....	6
4.	Multicone Ceiling Square / Rectangular Diffusers - Model DF/DF (AS) ..	9
5.	Perforated Face Diffusers - Model CPD .....	15
6.	Laminar Flow Diffusers - Model LFD .....	16
7.	Hi-Flo Jet Diffusers - Model RWH .....	19
8.	Large Format Circular Diffusers - Model WR .....	22
9.	Small Format Circular Diffusers - Model MC .....	24
10.	Spot Diffusers / Jet Nozzles - Model RSD .....	26
11.	Swirl Diffusers - Model WTF .....	28
12.	Adjustable Vane Diffusers - Model ACD .....	30
13.	Exhaust Valves - Model VB .....	32



## Range of Diffusers and Selection Procedure



**Continuous Slot  
Diffusers**  
Model CS-F

The required airflow in ltrs/sec per metre length of diffuser is marked on extreme left line, the radius of diffusion / NC level whichever is critical is marked on appropriate line. These two marks are connected and the line is extended upto the extreme right line to determine the no. of slots.

Refer page no. 5

The required airflow in ltrs/sec per metre length of diffuser is marked on extreme left line, the radius of diffusion / NC level whichever is critical is marked on appropriate line. These two marks are connected and the line is extended upto the extreme right line to determine the no. of slots.

Refer page no. 8

**Linear Diffusers**  
Model DSL

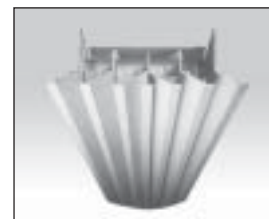

**Multicone Ceiling  
Square /  
Rectangular  
Diffusers**  
Model DF

The diffuser size for the particular core pattern can be selected from the performance data table by reading the airflow rate in ltrs/sec and the required radius of diffusion. The corresponding NC level and pressure drop can be directly read from table.

Refer page nos. 11 to 14

The diffuser size can be selected from the performance data table by reading the airflow rate in ltrs/sec and the required radius of diffusion. The corresponding NR level and pressure drop can be directly read from table.

Refer page no. 15

**Perforated Face  
Diffusers**  
Model CPD



**Laminar Flow  
Diffusers**  
Model LFD

The diffuser sizes are selected for the required airflow rate from the Table - 1. Average airstream velocity, airstream temperature, diffuser pressure loss, acoustic data can be read from Tables - 2, 3 & 4 respectively.

Refer page nos. 17 & 18

The size of diffuser is selected from the performance data table for the required airflow rate in ltrs/sec and the required throw in metres. The corresponding noise level and pressure drop can be read from table.

Refer page no. 20

**Hi-Flo Jet  
Diffusers**  
Model RWH





**Circular Diffusers**  
**Large Format**  
 Model WR

The size of diffuser is selected from the performance data table for the required airflow rate in ltrs/sec and the required throw in metres. The corresponding noise level and pressure drop can be read from table.

Refer page no. 23

The size of diffuser is selected from the performance data table for the required airflow rate in ltrs/sec and the required throw in metres. The corresponding noise level and pressure drop can be read from table.

Refer page no. 25

**Circular Diffusers**  
**Small Format**  
 Model MC



**Spot Diffusers /**  
**Jet Nozzles**  
 Model RSD

The size of diffuser is selected from the performance data table for the required airflow rate in ltrs/sec and the required throw in metres. The corresponding noise level and pressure drop can be read from table.

Refer page no. 27

The size of diffuser is selected from the performance data table for the required airflow rate in ltrs/sec and the required throw in metres. The corresponding noise level and pressure drop can be read from table.

Refer page no. 29

**Swirl Diffusers**  
 Model WTF



**Adjustable Vane**  
**Diffusers**  
 Model ACD

The required airflow in ltrs/sec is marked on the extreme left line, the throw/NC level whichever is critical is marked on appropriate line. These two marks are connected and the line is extended upto the pivot line. Any combination of diffuser width & height is selected by drawing a line passing through the point on pivot line.

Refer page no. 31

The size for the valve can be selected from the performance table for the required airflow rate in ltrs/sec. The corresponding pressure loss and dBA levels can be read directly from the table.

Refer page no. 32

**Exhaust Valves**  
 Model VB



## Continuous Slot Diffusers - Model CS-F

### Introduction

The Ravistar continuous slot diffusers series CS-F has for many years set the industry standard in terms of highest aerodynamic and acoustic performance. The model CS-F range is ideally suited to variable volume applications due to its excellent low flow rate air diffusion characteristics and high air handling capacity. The novel air pattern control element design allows any air pattern to be produced from 2 way horizontal diffusion to vertical projection, without any change in the facial appearance.

CS-F diffusers are suitable for all commercial and industrial projects requiring single or multislot diffusers for ceilings, bulkheads or sidewall supply and exhaust.

### Description

#### Manufacture

Diffusers are fabricated from high grade aluminium alloy extrusions fixed or clipped to cross stays allowing easy removal of internal vanes and pattern control elements.

#### Sizes

- Standard - from 1 to 8 slots wide.  
 - 1200mm long (excluding ends)  
 - continuous diffuser lengths are supplied in sections for butt-joining on-site. (alignment strips supplied).
- Special - multi-slot diffusers, (i.e. more than 8 slots) mitred joints and ceiling integration schemes up to 1800mm long refer to us.

#### Finish

- Standard a) Epoxy Polyester Powder Coated off white/pure white.  
 b) Natural anodised.  
 Other powder coating finishes available on request.

#### Ordering

Type	Length	No Slots	Accessories
CSF	6000	2	ENDS

#### Legend

- Type : Specify number of slots  
 Length : Nominal diffuser length excluding end caps. (specify overall length if necessary)  
 Accessories : End flanges, mitred corners horizontal or vertical 300 x 300mm.  
 Controls : HIT and MISS Dampers.

#### Features

- High air handling capacity
- Wide dynamic range for perfect VAV systems
- Strong Coanda effects for good low flow performance
- Fully adjustable air pattern from horizontal to vertical
- Hidden flow control vanes for consistent facial appearance
- Continuous joint detail for ceiling integrations.

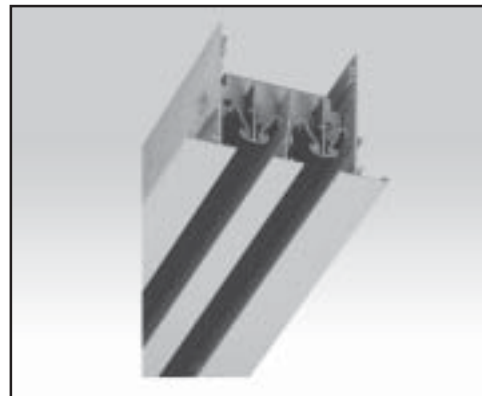

### Specification

Linear slot diffusers shall be Ravistar type CS-F incorporating two flow control vanes fixed to a central pattern control element on each slot. The air pattern shall be adjustable from horizontal to vertical without changing the appearance of the diffusers.

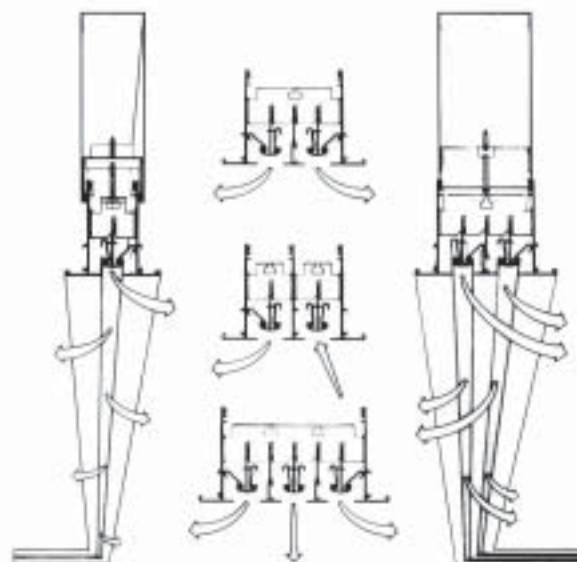

#### Flow Control Vanes

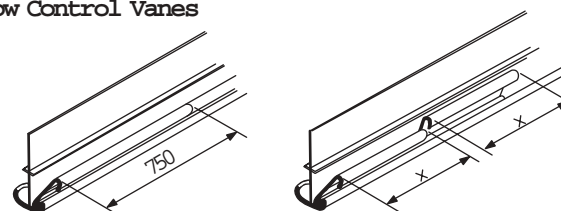

**Standard**  
 Diffusers are supplied with flow control vanes in lengths up to 750 mm (to suit diffuser length).

**Special**  
 To provide finer control of the air pattern, flow control vanes may be supplied in any specified lengths.

Dimensions

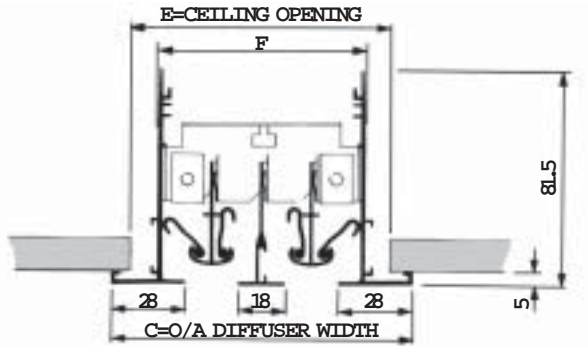

CS-F (Flanged Type Frame)

Number of Slots								
	1	2	3	4	5	6	7	8
C	76	114	152	190	228	266	304	343
E	57	95	133	171	209	247	285	324
F	40	79	117	155	193	231	269	307

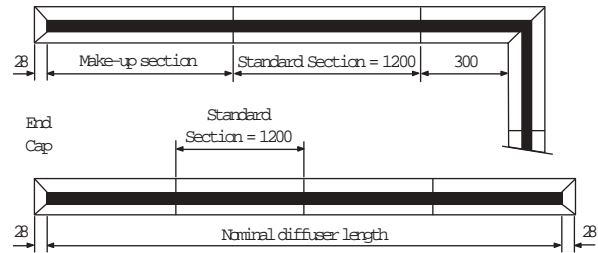

Accessories

End flanges, mitred corners horizontal or vertical 300 x 300mm.

Installation

Typical installation details

ducted supply & exhaust

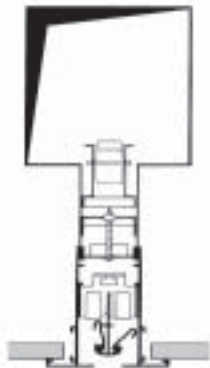

Short stub off main duct to accommodate diffuser and controls.

ceiling void exhaust

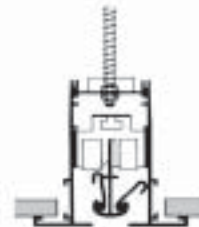

Ceiling void exhaust air diffusers (use flow control vanes for balancing). Also for dummy (inactive) sections.

Diffuser supported from Plenum Chamber



Plenum installed where required on Diffuser run

Ceiling Grid

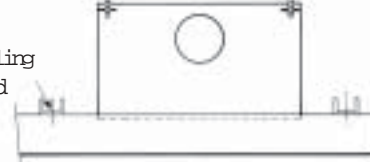

## Performance

Continuous Slot Diffuser

Type : CS-F

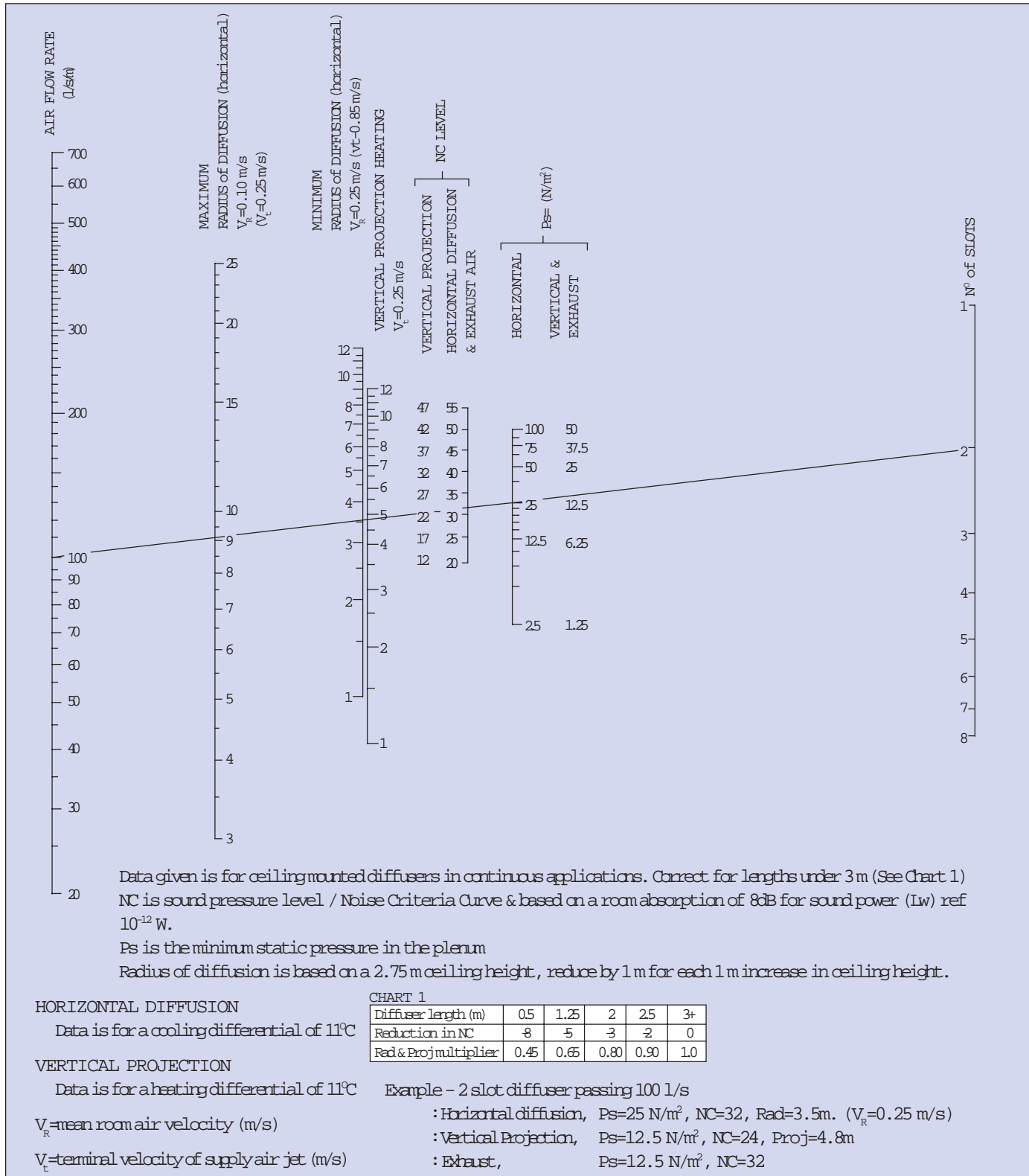

## Linear Diffusers - Model DSL

### Introduction

Large format linear diffusers are ideal for most commercial supply and exhaust systems and integrate well with ceiling tile and lighting layouts. The clean design provides an extremely low air resistance characteristic and this makes the diffuser ideal for any fan coil or induction system which is pressure sensitive. Single or multislot diffusers are available with fixed 1 or 2 way air patterns; multi-slot 2 way diffusers may be adjusted to suit site conditions by changing vanes. Pattern control vanes may be easily removed for installation, access or cleaning. A range of plenum chambers to suit DSL diffusers is available as an option.

### Description

#### Manufacture

Diffusers are constructed from high grade aluminium alloy extrusions fixed or clipped to cross stays. Internal vanes are removable for installation purposes.

### Types

DSL - One way discharge

DSL-D - Two way discharge

### Sizes

Standard - Single or multislot.

Standard length = 1200mm (For site butt joining).

Shorter Modular lengths to suit.

Special - multi-slot diffusers, (i.e. more than 8 slots) mitred joints and ceiling integration schemes up to 1800mm long refer to us.

### Dimensions

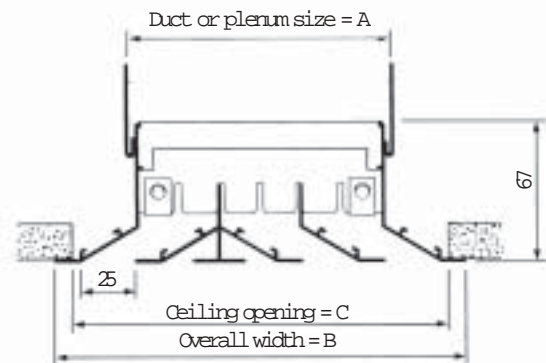
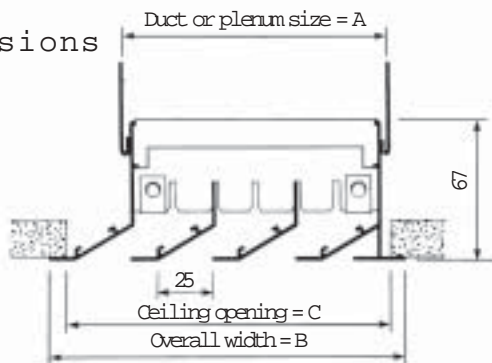

Type	A	B	C
DSL-1	46	89	70
DSL-2	84	127	108
DSL-3	122	165	146
DSL-4	160	203	184
DSL-5	198	241	222
DSL-6	237	279	260
DSL-7	275	317	298
DSL-8	313	355	336

### Features

- Ultra low pressure loss characteristics suited to fan coil and induction supply systems.
- Single or multislot to suit most air handling requirements.
- Clean design for practical integration with lighting or ceiling systems.
- Fixed 1 or 2 way pattern to prevent unwanted adjustment of air diffusion.

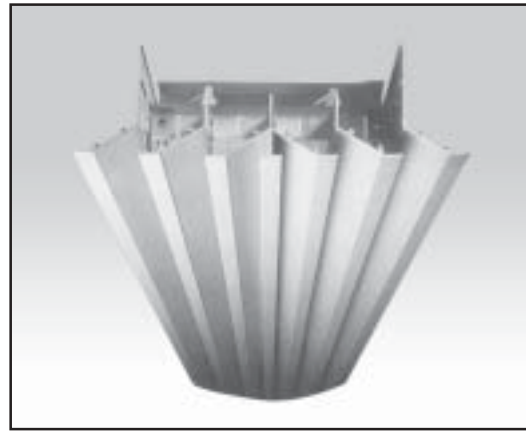

Type	A	B	C
DSL-D11	84	154	137
DSL-D12	122	192	175
DSL-D22*	160	230	213
DSL-D23*	198	268	251
DSL-D33*	237	306	289
DSL-D34*	275	345	327
DSL-D44*	313	382	365

\* Please specify number of slots in each direction.

### Installation

Standard fixing for 2 to 8 slot diffusers is by means of mounting brackets which are fitted into plenum chambers (or hemmed ducts). After removing the inner vanes the diffuser is raised up to the fixed plenum chamber or duct through the ceiling opening and fixed to the mounting brackets with screws provided; this system allows for a tolerance of 25mm between duct and ceiling levels. Finally replace inner vanes. Continuous diffusers are supplied with alignment strips for each vane and frame section.

### Finish

- Standard
- a) Epoxy Polyester Powder Coated off white/pure white.
  - b) Natural anodised.
- Other powder coating finishes available on request.

### Accessories

- OBD - opposed blade dampers
- ED - equalising deflectors
- Blanking Plates
- End Caps

### Specification

Linear diffusers shall be Ravistar type DSL having 38mm pitch vanes and fixed 1 or 2 way horizontal diffusion patterns. Internal vanes shall be individually removable for installation purposes.

Typical face view and dimensions

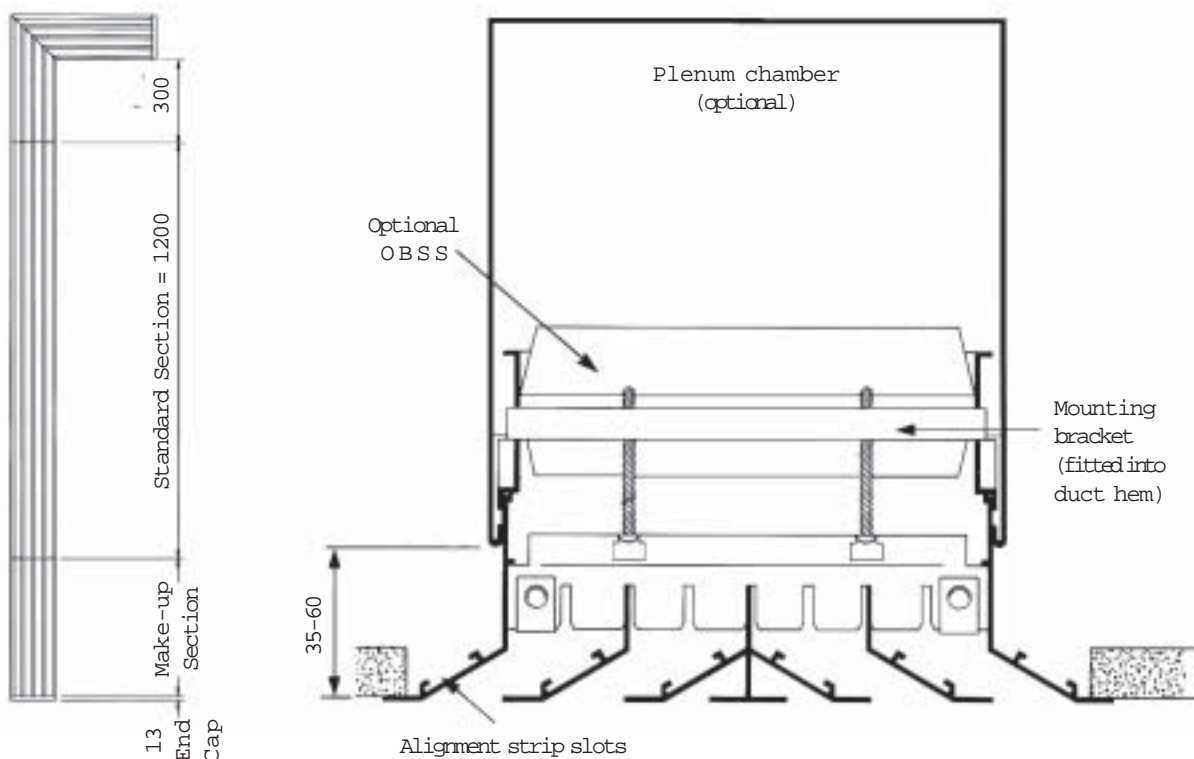

### Ordering

Type	Length	No Slots	Accessories
DSL	6000	3	ENDS

### Legend

- Type : Specify frame style and number of slots.
- Length : Nominal diffuser length.
- Accessories : End caps, blanking plates etc.

**Note :** To order separately for OBSS, ED etc.

## Performance

Linear Diffuser

Types : DSL, DSL-D

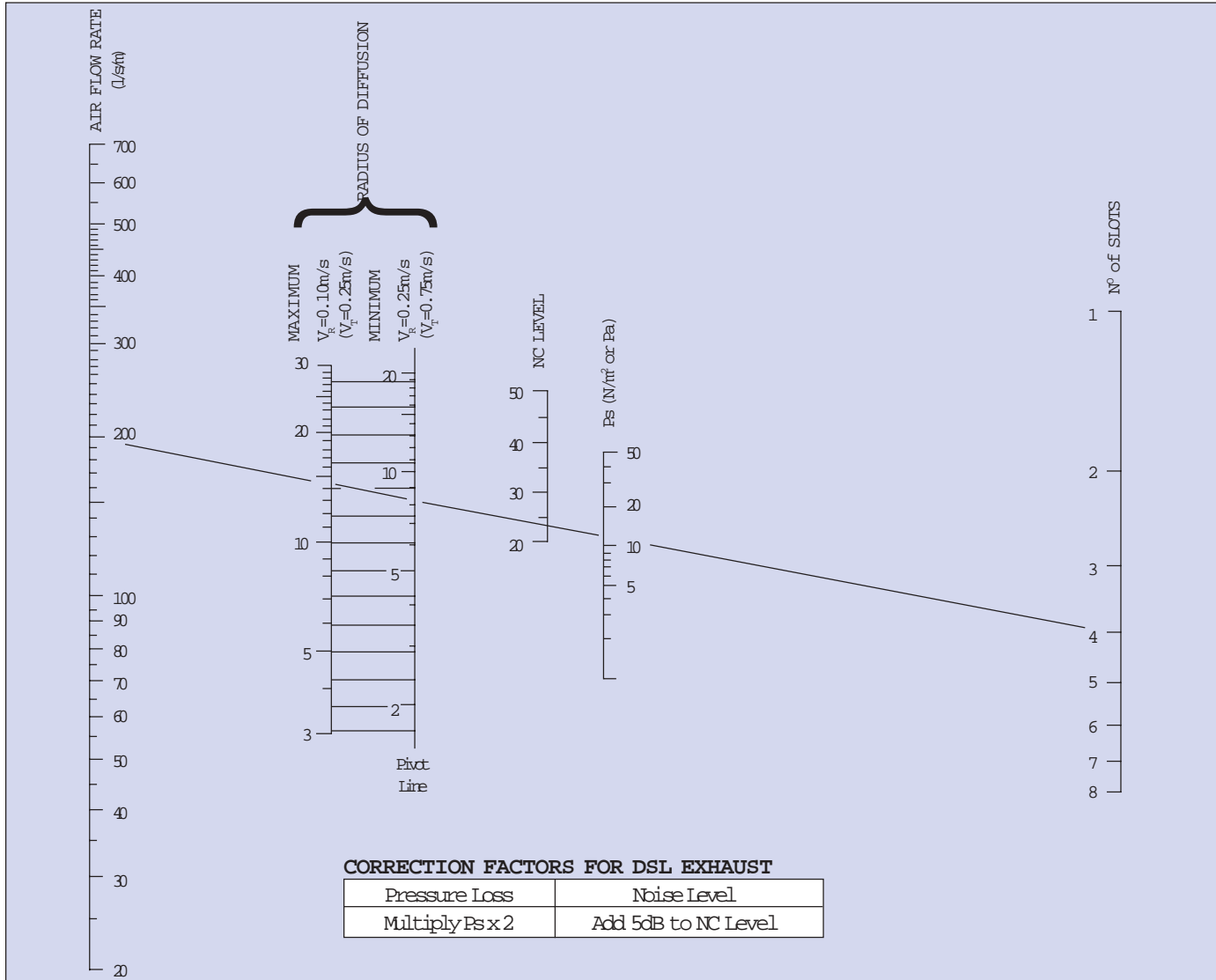

Data given is for diffusers in continuous applications supplying air at an 11°C cooling differential. Correct for lengths under 3m & for ED blades using tables below.

NC is sound pressure level/Noise Criteria Curve & based on a room absorption of 8dB for sound power (Iw) ref 10<sup>-12</sup> W

Ps is the minimum static pressure in the plenum.

Radius of diffusion is based on a 3m ceiling height, reduce by 300mm for each 300mm increase in ceiling height.

**LENGTH CORRECTION**

Diffuser length (m)	0.5	1.25	2.0	2.5	3.0
Reduction in NC	8	5	3	2	0
Radius multiplier	0.45	0.65	0.80	0.90	1.00

**EQUALIZING DEFLECTOR CORRECTION**

Diffuser length (m)	0.5	0.75	1.0	1.5
Radius Multiplier using E.D. Blades	0.33	0.42	0.48	0.54

Example : DSL-4 handling 200 ltrs/s/m (continuous)  
 Rad. of diff. = 8m ( $V_R=0.25$  m/s)  
 14m ( $V_R=0.10$  m/s)  
 Ps = 13 N/m<sup>2</sup>  
 NC = 23

$V_R$  = Mean room air velocity in the occupied zone  
 $V_T$  = Terminal velocity of supply air jet at the stated throw or radius of diffusion

## Multicone Ceiling Square / Rectangular Diffusers - Model DF/DF (AS)

### Introduction

Model DF Multicone diffusers, constructed from high grade aluminium alloy extrusions, are ideal for most commercial projects requiring high quality diffusers for integration with a variety of ceiling types. The range is available with 14 different air pattern control core designs for horizontal diffusion. Special diffusers are available with out - to - out size of 595 x 595 (with different neck sizes) for ceiling tile replacement. Diffusers are also available with anti smudge type borders.

### Description

#### Manufacture

Diffusers are constructed entirely from aluminium alloy extrusions with mitred and cleated frames.

#### Sizes

Square - minimum 150 x 150 duct size  
 maximum 600 x 600 duct size  
 Rectangular - minimum 150 x 150 duct size  
 maximum 1200 x 600 duct size  
 (each dimension increasing in increments of 75mm)

#### Finish

Standard : Epoxy Polyester Powder Coated off white/pure white.  
 Other powder coating finishes available on request.

#### Accessories

OBSS -duct mounted opposed blade damper.

#### Specification

Square and Rectangular multicone diffusers shall be Ravistar type DF made from aluminium extrusions with mitred frames.

#### Ordering

Type	Size		Core Style	Accessories
	Width	Height		
DF	300	300	41	OBSS

#### Legend

Type : DF  
 Core : see core options on page (10)  
 Accessories : OBSS  
 Size : nominal diffuser and duct size (mm)

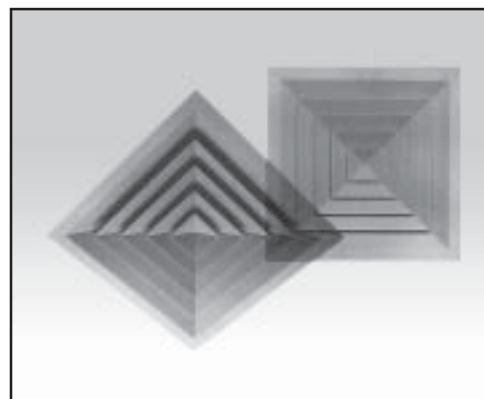

### Features

- Two frame styles for integration with most ceilings.
- 14 core styles to suit required air pattern.
- Lightweight aluminium construction.
- Fixed or adjustable patterns.
- Suits 300, 600, 1200 ceiling grid systems.

### Types and Dimensions

#### Diffuser with Flush Type Border DF

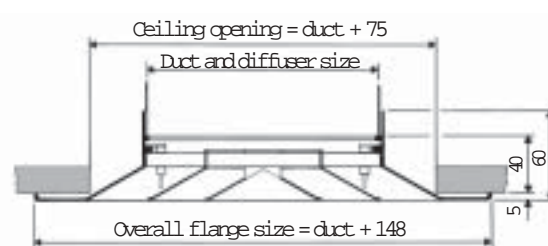

#### Diffuser with Anti Smudge Border DF (AS)

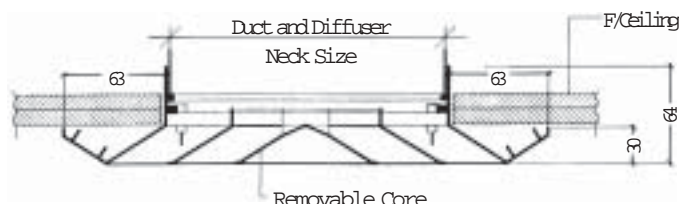

### Installation

#### Installation into stub ducts

Diffusers should be fixed rigidly to stub ducts by drilling through the neck and riveting or screwing. This may be achieved from below the ceiling line by removing the core and fixing from inside the neck.

#### Installation with Plenum Chambers

The plenum chamber should be rigidly fixed to the soffit or grid and the diffuser fixed in turn to the plenum.

### Controls

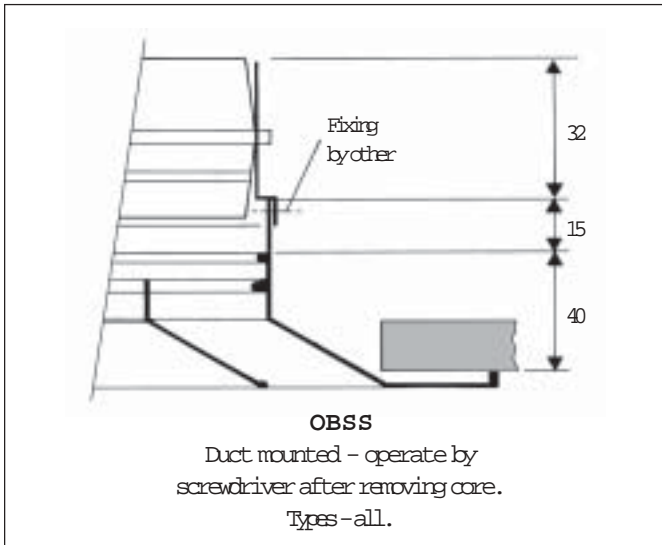

### Performance

Performance data is given on pages 11 to 14 inclusive for supply air diffusers. Data should be corrected for exhaust applications and for situations where neck mounted opposed blade dampers are used.

Application	NC Addition	P <sub>s</sub> Multiplier
Supply diffuser	0 dB	1.0
Supply diffuser + OBSS	+ 3 dB	1.0
Exhaust diffuser	+ 3 dB	1.10
Exhaust diffuser + OBSS	+ 13dB	1.15

Additional noise generated by throttling the opposed blade damper can be estimated from the graph below.

$$\text{Pressure Ratio} = \frac{\text{Available duct pressure}}{\text{Diffuser + open OBSS pressure}}$$

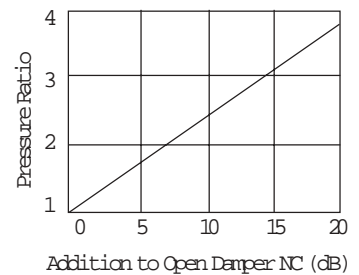

### Core Styles

#### Square

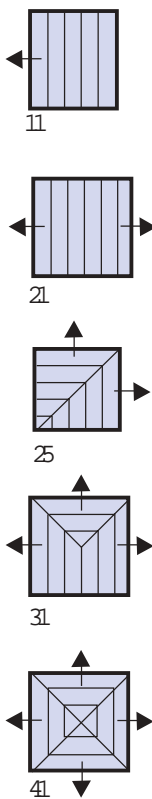

#### Rectangular

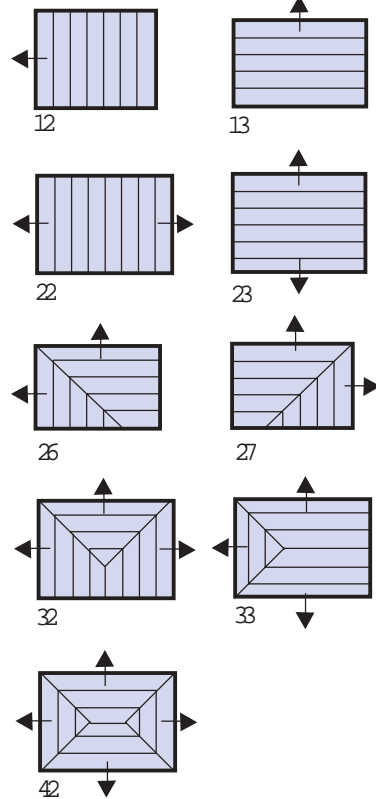

#### Basis of Data

Radius of Diffusion - Minimum and maximum throw which results in an average air velocity within the occupied zone of 0.25 m/s and 0.10 m/s respectively.

NC Level - Peak level on Noise Criteria curves based on sound power level less 8dB room absorption.

P<sub>t</sub> - total pressure drop (Pa)

Performance Data DF

core pattern	SIZE neck dims. (mm)	NECK VELOCITY (m/s)					
		RATING	1.5	2	2.5	3	3.5
		total pressure drop (Pa)	9	15	23	33	43
 11	150 x 150	1s NC LEVEL MIN-MAX RAD (m)	34 - 1.5-2.5	45 - 2-3.5	56 20 2-4.5	68 24 2.5-5.5	79 28 3-6
	225 x 225	1s NC LEVEL MIN-MAX RAD (m)	76 - 2-4	101 20 2.5-5.5	127 25 3.5-6.5	152 29 4-8	177 32 4.5-9
	300 x 300	1s NC LEVEL MIN-MAX RAD (m)	135 - 2.5-5.5	180 23 3.5-6.5	225 28 4.5-8.5	270 32 5-10.5	315 35 6.5-12
	375 x 375	1s NC LEVEL MIN-MAX RAD (m)	211 - 3.5-6.5	282 25 4.5-8.5	352 30 5.5-11	422 34 6.5-13.5	492 37 7.5-15
 12	225 x 150	1s NC LEVEL MIN-MAX RAD (m)	51 - 2-3.5	68 - 2-4.5	84 23 2.5-5.5	101 27 3.5-6.5	118 30 4-7.5
	300 x 225	1s NC LEVEL MIN-MAX RAD (m)	101 - 2.5-5	135 22 3-6	169 27 4-8	203 30 4.5-9	236 34 5-10.5
	375 x 300	1s NC LEVEL MIN-MAX RAD (m)	169 - 2.5-6	225 24 4-8	281 29 5-10	338 33 6-12	394 36 7-13.5
 13	225 x 150	1s NC LEVEL MIN-MAX RAD (m)	51 - 2-3.5	68 - 2-4.5	84 23 2.5-5.5	101 27 3.5-6.5	118 30 4-7.5
	300 x 150	1s NC LEVEL MIN-MAX RAD (m)	68 - 2-3.5	90 - 2.5-5	113 24 3-6	135 28 4-7.5	158 32 4.5-8.5
	375 x 150	1s NC LEVEL MIN-MAX RAD (m)	84 - 2-4	113 20 2.5-6	141 26 3.5-6.5	169 29 4-8	197 33 5-10
	450 x 150	1s NC LEVEL MIN-MAX RAD (m)	101 - 2.5-5	135 22 3-6	169 27 4-7.5	203 30 4.5-9	236 34 5-10.5
	300 x 225	1s NC LEVEL MIN-MAX RAD (m)	101 - 2.5-5	135 22 3-6	169 27 4-7.5	203 30 4.5-9	236 34 5-10.5
	375 x 225	1s NC LEVEL MIN-MAX RAD (m)	127 - 2.5-5	169 22 3.5-6.5	211 27 4.5-8.5	253 32 5-10	295 35 6-12
	525 x 225	1s NC LEVEL MIN-MAX RAD (m)	177 - 3-6	237 24 4-8	295 29 5-10	354 33 6-12	413 37 7-14
	375 x 300	1s NC LEVEL MIN-MAX RAD (m)	169 - 2.5-6	225 24 4-8	291 29 5-10	338 33 6-11.5	394 36 7-13.5
	450 x 300	1s NC LEVEL MIN-MAX RAD (m)	203 - 3.5-6.5	270 25 4.5-8.5	338 30 5-10.5	405 33 6.5-13	473 37 7.5-15
	525 x 300	1s NC LEVEL MIN-MAX RAD (m)	236 20 3.5-7	315 26 4.5-9	394 30 6-11.5	473 34 7-14	551 37 8-16
 21	150 x 150	1s NC LEVEL MIN-MAX RAD (m)	34 - 1-2	45 - 1-2.5	56 20 1.5-3	68 24 2-3.5	79 28 2-4.5
	225 x 225	1s NC LEVEL MIN-MAX RAD (m)	76 - 1.5-2.5	101 20 2.5-5	127 25 2.3-5	152 29 2.5-5.5	177 32 3-6
	300 x 300	1s NC LEVEL MIN-MAX RAD (m)	135 - 2-3.5	180 23 2.5-5	225 28 3-6	270 32 3.5-7.5	315 35 4.5-8.5
	375 x 375	1s NC LEVEL MIN-MAX RAD (m)	211 - 2.5-4.5	282 25 3-6	352 30 4-7.5	422 34 5-9.5	492 37 5.5-11
	450 x 450	1s NC LEVEL MIN-MAX RAD (m)	304 21 2.5-6	405 27 3.5-7.5	506 32 4.5-9	608 35 5.5-11	709 39 6.5-13
 22	225 x 150	1s NC LEVEL MIN-MAX RAD (m)	51 - 1-2.5	63 - 1.5-3	84 23 2-3.5	101 27 2-4.5	118 30 2.5-5
	300 x 150	1s NC LEVEL MIN-MAX RAD (m)	68 - 1.5-2.5	90 - 2-3.5	113 24 2-4.5	135 23 2.5-5	158 32 3-6
	300 x 225	1s NC LEVEL MIN-MAX RAD (m)	101 - 2-3.5	135 22 2-4.5	169 27 2.5-5	203 30 3.5-6.5	236 34 4-7.5
	375 x 225	1s NC LEVEL MIN-MAX RAD (m)	127 - 2-3.5	169 22 2.5-5	211 27 3-6	253 32 3.5-7.5	295 35 4.5-8.5
	375 x 300	1s NC LEVEL MIN-MAX RAD (m)	169 - 2-4	225 24 2.5-5.5	281 29 3.5-7	338 33 4-8	394 36 5-9.5

core pattern	SIZE	NECK VELOCITY (m/s)										
		RATING	1.5		2		2.5		3		3.5	
			total pressure drop (Pa)	9		15		23		33		43
neck dims. (mm)		L	S	L	S	L	S	L	S	L	S	
<p>23</p>	225 x 150	ls NC LEVEL MIN-MAX RAD (m)	51 - 1-2.5	- - 1.5-3	63 - 1.5-3	- - 2-4.5	84 23 2-3.5	- 27 2-4.5	101 27 2-4.5	- 30 2.5-5	118 30 2.5-5	-
	300 x 150	ls NC LEVEL MIN-MAX RAD (m)	63 - 1.5-2.5	- - 2-3.5	90 - 2-3.5	- - 2-4.5	113 24 2-4.5	- 28 2.5-5	135 28 2.5-5	- 32 3-6	158 32 3-6	-
	375 x 150	ls NC LEVEL MIN-MAX RAD (m)	84 - 1.5-3	- - 2-4	113 20 2-4	- - 2.5-5	141 26 2.5-5	- 29 2.5-6	169 29 2.5-6	- 33 3.5-7	197 33 3.5-7	-
	450 x 150	ls NC LEVEL MIN-MAX RAD (m)	101 - 2-3.5	- - 2-4.5	135 22 2-4.5	- - 2.5-5.5	169 27 2.5-5.5	- 30 3.5-6.5	203 30 3.5-6.5	- 34 4-7.5	236 34 4-7.5	-
	300 x 225	ls NC LEVEL MIN-MAX RAD (m)	101 - 2-3.5	- - 2-4.5	135 22 2-4.5	- - 2.5-5.5	169 27 2.5-5.5	- 30 3.5-6.5	203 30 3.5-6.5	- 34 4-7.5	236 34 4-7.5	-
	375 x 225	ls NC LEVEL MIN-MAX RAD (m)	127 - 2-4	- - 2.5-5	169 22 2.5-5	- - 3-6	211 27 3-6	- 32 3.5-7.5	253 32 3.5-7.5	- 35 4.5-8.5	295 35 4.5-8.5	-
	525 x 225	ls NC LEVEL MIN-MAX RAD (m)	177 - 2-4.5	- - 2.5-6	237 24 2.5-6	- - 3.5-7.5	295 29 3.5-7.5	- 33 4.5-8.5	354 33 4.5-8.5	- 37 5-10	413 37 5-10	-
	375 x 300	ls NC LEVEL MIN-MAX RAD (m)	169 - 2-4	- - 2.5-6	225 24 2.5-6	- - 3.5-7	281 29 3.5-7	- 33 4-8	338 33 4-8	- 36 5-9.5	394 36 5-9.5	-
	450 x 300	ls NC LEVEL MIN-MAX RAD (m)	203 - 2.5-4.5	- - 3-6	270 25 3-6	- - 4-8	338 30 4-8	- 33 4.5-9	405 33 4.5-9	- 37 5-10.5	473 37 5-10.5	-
	525 x 300	ls NC LEVEL MIN-MAX RAD (m)	236 20 2.5-5	- - 3.5-6.5	315 26 3.5-6.5	- - 4-8	394 30 4-8	- 34 5-10	473 34 5-10	- 37 6-11.5	551 37 6-11.5	-
450 x 375	ls NC LEVEL MIN-MAX RAD (m)	253 20 2.5-5	- - 3.5-6.5	338 26 3.5-6.5	- - 4.5-8.5	422 31 4.5-8.5	- 35 5-10	506 35 5-10	- 38 6-12	590 38 6-12	-	
<p>25</p>	150 x 150	ls NC LEVEL MIN-MAX RAD (m)	34 - 1-2	- - 1-2.5	45 - 1-2.5	- - 1.5-3	56 20 1.5-3	- 24 2-3.5	68 24 2-3.5	- 28 2-4.5	79 28 2-4.5	-
	225 x 225	ls NC LEVEL MIN-MAX RAD (m)	76 - 1.5-2.5	- - 2-3.5	101 20 2-3.5	- - 2.5-5	127 29 2.5-5	- 32 2.5-5.5	152 32 2.5-5.5	- 36 3-6	177 32 3-6	-
	300 x 300	ls NC LEVEL MIN-MAX RAD (m)	135 - 2-3.5	- - 2.5-5	180 23 2.5-5	- - 3-6	225 28 3-6	- 32 3.5-7.5	270 32 3.5-7.5	- 38 4.5-8.5	315 38 4.5-8.5	-
	375 x 375	ls NC LEVEL MIN-MAX RAD (m)	211 - 2.5-4.5	- - 3-6	282 25 3-6	- - 4-7.5	352 30 4-7.5	- 34 5-9.5	422 34 5-9.5	- 37 5.5-11	492 37 5.5-11	-
	450 x 450	ls NC LEVEL MIN-MAX RAD (m)	304 21 2.5-6	- - 3.5-7.5	405 27 3.5-7.5	- - 4.5-9	506 32 4.5-9	- 35 5.5-11	608 35 5.5-11	- 39 6.5-13	709 39 6.5-13	-
<p>26</p>	225 x 150	ls NC LEVEL MIN RAD (m) MAX RAD (m)	51 - 1.5 1 2.5 2	- - 2 1 3.5 2.5	68 - 2 1 3.5 2.5	84 23 2 2 4.5 3.5	- 27 2.5 2 5 4	101 27 2.5 2 5 4	- 30 3 2 6 4.5	118 30 3 2 6 4.5	-	
	300 x 150	ls NC LEVEL MIN RAD (m) MAX RAD (m)	68 - 2 1 3.5 2	- - 2 1 4.5 2.5	90 - 2 1 4.5 2.5	113 24 2.5 2 5 3.5	- 28 3.5 2 6.5 4	135 28 3.5 2 7.5 4	- 32 4 2 7.5 4.5	158 32 4 2 7.5 4.5	-	
	375 x 150	ls NC LEVEL MIN RAD (m) MAX RAD (m)	84 - 2 1 4 2	- - 2.5 1 5 2.5	113 20 2.5 1 5 2.5	141 26 3 2 6 3.5	- 23 4 2 7.5 4	169 23 4 2 7.5 4	- 33 4.5 2 10.5 8.5	197 33 4.5 2 8.5 4.5	-	
<p>27</p>	300 x 225	ls NC LEVEL MIN RAD (m) MAX RAD (m)	101 - 2 1.5 4 3	- - 2.5 2 5 4	135 22 2.5 2 5 4	169 27 2.5 2.5 6 5	- 30 3.5 2.5 7.5 6	203 30 3.5 2.5 7.5 6	- 34 4.5 3.5 8 6.5	236 34 4.5 3.5 8 6.5	-	
	375 x 300	ls NC LEVEL MIN RAD (m) MAX RAD (m)	169 - 2.5 2 5 4	- - 3 2.5 6 5	225 24 3 2.5 6 5	281 29 4 3 7.5 6	- 33 4.5 4 9 7.5	338 33 4.5 4 10.5 7.5	- 36 5 4.5 12 8.5	394 36 5 4.5 10.5 8.5	-	
	450 x 300	ls NC LEVEL MIN RAD (m) MAX RAD (m)	203 - 2.5 2 5 4	- - 3.5 2.5 7 5	270 25 3.5 2.5 7 5	338 30 4.5 3 9 6	- 33 5 4 10.5 7.5	405 33 5 4 10.5 7.5	- 37 6 4.5 12 8.5	473 37 6 4.5 12 8.5	-	
<p>31</p> <p>S = Short side throw    L = Long side throw</p>	150 x 150	ls NC LEVEL MIN RAD (m) MAX RAD (m)	34 - 1 1 2 2	- - 1 1 2 2	45 - 1 1 2 2	56 20 1.5 1 2.5 2	- 24 2 1.5 3.5 2.5	63 24 2 1.5 3.5 2.5	- 28 2 2 4 3.5	79 28 2 2 4 3.5	-	
	225 x 225	ls NC LEVEL MIN RAD (m) MAX RAD (m)	76 - 1 1 2.5 2	- - 2 1 3.5 2.5	101 20 2 1 3.5 2.5	127 25 2 2 4 3.5	- 29 2.5 2 5 4.5	152 29 2.5 2 5 4.5	- 32 2.5 2 6 4.5	177 32 2.5 2 6 4.5	-	
	300 x 300	ls NC LEVEL MIN RAD (m) MAX RAD (m)	135 - 2 1.5 3.5 3	- - 2 2 4.5 4	180 23 2 2 4.5 4	225 28 2.5 2 5 4.5	- 32 3.5 2.5 6.5 5	270 32 3.5 2.5 6.5 5	- 35 4 3 7.5 6	315 35 4 3 7.5 6	-	

core pattern	SIZE neck dims. (mm)	NECK VELOCITY (m/s)										
		RATING total pressure drop (Pa)	1.5		2		2.5		3		3.5	
			L	S	L	S	L	S	L	S	L	S
	375 x 375	1s NC LEVEL MIN RAD (m) MAX RAD (m)	211 - 2 4	2 2 3.5	282 25 2.5 5	2 2 4.5	352 30 3.5 6.5	2.5 2.5 5.5	422 34 4 8	3.5 3.5 6.5	492 37 5 9.5	4 4 7.5
	450 x 450	1s NC LEVEL MIN RAD (m) MAX RAD (m)	304 21 3.5 7	2.5 2.5 5	405 27 3.5 6.5	2.5 2.5 5	506 32 4 8	3.5 3.5 6.5	608 35 5 10	4 4 8	709 39 6 11.5	4.5 4.5 9
	225 x 150	1s NC LEVEL MIN RAD (m) MAX RAD (m)	51 - 1 2	1 1 2	63 - 1 2.5	1 1 2	84 23 2 3.5	1.5 1.5 3	101 27 2 4	2 2 3.5	118 30 2.5 4.5	1.5 2 4.5
	300 x 150	1s NC LEVEL MIN RAD (m) MAX RAD (m)	68 - 1.5 2.5	1 1 2	90 - 2 3.5	1 1 2	113 24 2 4.5	1.5 1.5 3	135 28 2.5 5	2 2 3.5	158 32 3 6	2 2 4.5
	375 x 150	1s NC LEVEL MIN RAD (m) MAX RAD (m)	84 - 2 3.5	1 1 2	113 20 2 4.5	1 1 2	141 26 2.5 5	1.5 1.5 3	169 29 3.5 6.5	2 2 3.5	197 33 4 7.5	2 2 4.5
	450 x 150	1s NC LEVEL MIN RAD (m) MAX RAD (m)	101 - 2 3.5	1 1 2	135 22 2.5 5	1 1 2	169 27 3 6	1.5 1.5 3	203 30 4 7.5	2 2 3.5	236 34 4.5 8.5	2 2 4.5
	300 x 225	1s NC LEVEL MIN RAD (m) MAX RAD (m)	101 - 1.5 3	1.5 1.5 3	135 22 2 4	2 2 4	159 27 2 4.5	2 2 4.5	203 30 2.5 5	2.5 2.5 5	236 34 3 6	3 3 6
	525 x 225	1s NC LEVEL MIN RAD (m) MAX RAD (m)	177 - 2.5 5	2 2 3.5	237 24 3 6	2.5 2.5 4.5	295 29 4 7.5	3 3 6	354 33 4.5 9	3.5 3.5 7	413 37 5 10.5	4.5 4.5 8
	375 x 300	1s NC LEVEL MIN RAD (m) MAX RAD (m)	169 - 2 3.5	2 2 3.5	225 24 2.5 5	2 2 4.5	281 29 2.5 6	2.5 2.5 5.5	338 33 3.5 7.5	3.5 3.5 6.5	394 36 4 8	4 4 7.5
	450 x 300	1s NC LEVEL MIN RAD (m) MAX RAD (m)	203 - 2 4	2 2 3.5	270 25 2.5 5	2.5 2.5 5	333 30 3.5 6.5	2.5 2.5 6	405 33 4 8	3.5 3.5 7.5	473 37 4.5 9	4 4 8
	450 x 375	1s NC LEVEL MIN RAD (m) MAX RAD (m)	253 20 2 4.5	2 2 4	338 26 2.5 5.5	2.5 2.5 5	422 31 3.5 7.5	3.5 3.5 6.5	506 35 4.5 3.5	4 4 8	580 38 5 10	4.5 4.5 9
	525 x 450	1s NC LEVEL MIN RAD (m) MAX RAD (m)	354 22 2.5 5	2.5 2.5 5	473 28 3.5 6.5	3 3 6	591 32 4.5 8.5	4 4 7.5	709 37 5 10	4.5 4.5 9	827 40 6 12	5.5 5.5 11
	225 x 150	1s NC LEVEL MIN RAD (m) MAX RAD (m)	51 - 1 2	1 1 1.5 2	68 - 1.5 2.5	1 1 2	84 23 2 3.5	1 1 2.5	101 27 2 4.5	1.5 1.5 2.5	118 30 2.5 5	1.5 1.5 3
	300 x 150	1s NC LEVEL MIN RAD (m) MAX RAD (m)	68 - 1.5 2.5	1 1 1.5	90 - 2 3.5	1 1 2	113 24 2 4.5	1.5 1.5 2.5	135 28 2.5 5	1.5 1.5 2.5	158 32 2.5 6	1.5 1.5 3
	375 x 150	1s NC LEVEL MIN RAD (m) MAX RAD (m)	84 - 1.5 2.5	1 1 1.5	113 20 2 3.5	1 1 2	141 26 2.5 4.5	1.5 1.5 2.5	169 29 3.5 5.5	1.5 1.5 2.5	197 33 3.5 6.5	1.5 1.5 3
	300 x 225	1s NC LEVEL MIN RAD (m) MAX RAD (m)	101 - 1.5 2.5	1 1 2	135 22 2 4	1.5 1.5 2.5	169 27 2.5 5	2 2 3.5	203 30 2.5 6	2 2 3.5	236 34 3.5 7	2.5 2.5 5
	375 x 225	1s NC LEVEL MIN RAD (m) MAX RAD (m)	127 - 2 3.5	1 1 2	169 22 2 4.5	1.5 1.5 2.5	211 27 2.5 5.5	2 2 3.5	253 32 3.5 6.5	2 2 4	295 35 4 8	2.5 2.5 5
	525 x 225	1s NC LEVEL MIN RAD (m) MAX RAD (m)	177 - 2 4	1 1 2	237 24 2.5 5	1.5 1.5 2.5	295 29 3.5 6.5	2 2 3.5	354 33 4 8	2 2 4	413 37 5 10	2.5 2.5 5
	375 x 300	1s NC LEVEL MIN RAD (m) MAX RAD (m)	169 - 2 4	1.5 1.5 2.5	225 24 2.5 5	2 2 3.5	281 29 3 6	2 2 4.5	338 33 4 7.5	2.5 2.5 5	394 36 4.5 8.5	3 3 6
	450 x 300	1s NC LEVEL MIN RAD (m) MAX RAD (m)	203 - 2 4.5	1.5 1.5 2.5	270 25 2.5 5.5	2 2 3.5	338 30 3.5 7	2 2 4.5	405 33 4 8	2.5 2.5 5	473 37 5 9.5	3 3 6
	450 x 375	1s NC LEVEL MIN RAD (m) MAX RAD (m)	253 20 2.5 4.5	2 2 3.5	338 26 3 6	2 2 4.5	422 31 4 7.5	2.5 2.5 5.5	506 35 4.3 9	3.5 3.5 6.5	590 38 5 10.5	4 4 7.5
	525 x 450	1s NC LEVEL MIN RAD (m) MAX RAD (m)	354 22 2.5 5	2 2 4	473 28 3.5 7.5	2.5 2.5 5	591 32 4.5 9	3.5 3.5 6.5	709 37 5 10.5	4 4 7.5	827 40 6 12.5	4.5 4.5 9

S = Short side throw L = Long side throw

core pattern	SIZE	NECK VELOCITY (m/s)										
		RATING	1.5		2		2.5		3		3.5	
			total pressure drop (Pa)	9		15		23		33		43
neck dims. (mm)		L	S	L	S	L	S	L	S	L	S	
	150 x 150	ls NC LEVEL MIN MAX RAD (m)	34 - 1-1.5		45 - 1-2		56 - 1.5-2.5		68 - 1.5-3		79 19 2-3.5	
	225 x 225	ls NC LEVEL MIN MAX RAD (m)	76 - 1-2		101 - 1.5-2.5		127 - 2-3.5		152 23 2-4		177 27 2-4.5	
	300 x 300	ls NC LEVEL MIN MAX RAD (m)	135 - 1.5-2.5		180 20 2-3.5		225 25 2-4.5		270 29 2.5-5		315 32 3-6	
	375 x 375	ls NC LEVEL MIN MAX RAD (m)	211 - 2-3.5		282 24 2-4.5		352 29 2.5-5.5		422 33 3.5-6.5		492 37 4-7.5	
	450 x 450	ls NC LEVEL MIN MAX RAD (m)	304 22 2-4		405 28 2.5-5		506 33 3.5-6.5		608 36 4-8		709 40 4.5-9	
	525 x 525	ls NC LEVEL MIN MAX RAD (m)	413 25 2.5-5		551 31 3-6		689 36 4-8		827 39 4.5-9		964 43 5-10.5	
	600 x 600	ls NC LEVEL MIN MAX RAD (m)	540 27 2.5-5.5		720 33 3.5-7		900 38 4.5-8.5		1080 43 5-10.5		1260 46 6-12	
	225 x 150	ls NC LEVEL MIN RAD (m) MAX RAD (m)	51 - 1 2	1 1.5	68 - 1 2.5	1 2	84 - 1.5 3.5	1 2.5	101 - 2 3.5	1.5 3	118 23 2 4.5	2 3.5
	300 x 150	ls NC LEVEL MIN RAD (m) MAX RAD (m)	68 - 1 2.5	1 1.5	90 - 1.5 3.5	1 2	113 - 2 3.5	1 2.5	135 - 2 4.5	1.5 3	158 25 2.5 5	2 3.5
	375 x 150	ls NC LEVEL MIN RAD (m) MAX RAD (m)	84 - 1.5 3	1 1.5	113 - 2 3.5	1 2	141 20 2 4.5	1 2.5	169 24 2.5 5	1.5 3	197 28 3 6	2 3.5
	450 x 150	ls NC LEVEL MIN RAD (m) MAX RAD (m)	101 - 1.5 3.5	1 1.5	135 - 2 4	1 2	169 22 2.5 5	1 2.5	203 26 2.5 6	1.5 3	236 30 3.5 6.5	2 3.5
	300 x 225	ls NC LEVEL MIN RAD (m) MAX RAD (m)	101 - 1 2.5	1 2	135 - 2 3.5	1 2.5	169 22 2 4.5	2 3.5	203 26 2.5 5	2 4	236 36 2.5 6	2 4.5
	375 x 225	ls NC LEVEL MIN RAD (m) MAX RAD (m)	127 - 1.5 3	1 2	169 20 2 3.5	1 2.5	211 24 2 4.5	2 3.5	253 28 3 6.5	2 4	295 32 3.5 7.5	2 4.5
	525 x 225	ls NC LEVEL MIN RAD (m) MAX RAD (m)	177 - 2 4	1 2	237 23 2.5 5	1 2.5	295 27 3 6	2 3.5	354 32 4 7.5	2 4	413 35 4.5 8.5	2 4.5
	375 x 300	ls NC LEVEL MIN RAD (m) MAX RAD (m)	169 - 2 3.5	1 2.5	225 22 2 4.5	2 3.5	281 27 2.5 5	2 4	338 31 3.5 6.5	2.5 5	394 34 4 7.5	3 6
	450 x 300	ls NC LEVEL MIN RAD (m) MAX RAD (m)	203 - 2 3.5	1 2.5	270 24 2.5 5	2 3.5	338 28 3 6	2 4.5	405 33 4 8	2.5 5	473 36 4.5 8	3 6
	525 x 300	ls NC LEVEL MIN RAD (m) MAX RAD (m)	236 - 2 4.5	1 2.5	315 25 2.5 6	2 3.5	384 30 3.5 6.5	2 4.5	473 34 4 8	2.5 5	551 37 5 9.5	3 6
	450 x 375	ls NC LEVEL MIN RAD (m) MAX RAD (m)	253 20 2 4	2 3.5	338 26 2.5 5	2 4.5	422 31 3.5 6.5	2.5 5.5	506 35 4 7.5	3.5 6.5	590 38 4.5 9	4 7.5
	525 x 375	ls NC LEVEL MIN RAD (m) MAX RAD (m)	295 21 2 4.5	2 3.5	394 27 2.5 6	2 4.5	492 32 3.5 7.5	2.5 5.5	591 36 4.5 8.5	3.5 6.5	689 40 5 10.5	4 7.5
	525 x 450	ls NC LEVEL MIN RAD (m) MAX RAD (m)	354 23 2.5 5	2 4	473 29 3 6	2.5 5	591 34 4 7.5	3.5 6.5	709 38 4.5 9	4 8	827 41 5 10.5	4.5 9
	600 x 450	ls NC LEVEL MIN RAD (m) MAX RAD (m)	405 24 2.5 5	2 4	540 31 3.5 7	2.5 5	675 36 4.5 8.5	3.5 6.5	810 39 5 10	4 8	945 43 6 12	4.5 9

S = Short side throw    L = Long side throw

## Perforated Face Diffusers - Model CPD

### Introduction

The CPD range of diffusers have been designed for use in commercial applications and are particularly suited to projects with high air change rates and high cooling differentials. Diffusers are suitable for installation in 600 tile module systems. The aluminium face plate can be removed with 4 nos. spring loaded latches to ease installation, commissioning and maintenance.

### Description

Diffusers are constructed from aluminium frames and perforated face plates. The diffuser cores are removable type and damper operation from front.

### Sizes

Available in 4 neck sizes 225 x 225, 300 x 300, 375 x 375 & 450 x 450 standard face size of 595 x 595.

### Features

- Integrate with 600mm tile sizes.
- All aluminium face construction.
- Removable face plate.
- Removable core.
- High air handling capacity.
- Supply or exhaust diffusers visually compatible.

### Control Dampers

OBSS - Opposed Blade Damper

### Finish

- Standard
- Epoxy Polyester Powder Coated off white/pure white.
  - Natural anodised.
- Other powder coating finishes available on request.

### Typical specification

Perforated face ceiling diffuser with aluminium frame and perforated plate. Diffuser shall incorporate a quick release perforated plate which can be easily removed to allow installation, commissioning and maintenance.

### Performance Data - CPD Supply Air Diffuser Only

Typical performance for diffuser with neck size 300 x 300 mm & face size 595 x 595 mm.

Pattern	Velocity m/s		2	3	4	5	6
	Air FlowRate (l/s)		141	212	282	356	424
4 WAY	Radius of diffusion	min (m)	1.0	1.5	2.1	2.7	3.3
		max (m)	2.3	3.6	5.0	6.2	7.7
	Pressure loss	Ps (Pa)	3	6	10	16	23
	NR level		18	27	36	44	53



### Ordering

When ordering specify neck size.

Typical Designation

Type	W	H	Neck Size	Control Damper
CPD	595	595	300 x 300	OBSS

### Legend

- Type : CPD  
 Controls : OBSS  
 Size : Neck Size

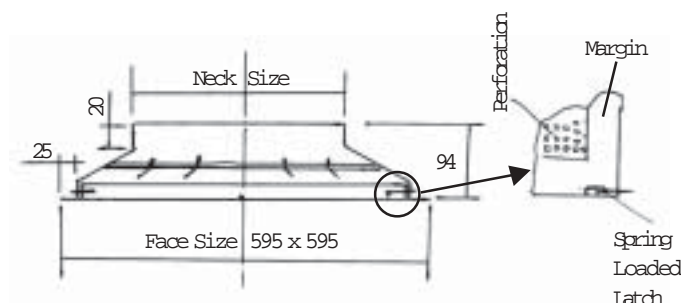

## Laminar Flow Diffusers - Model LFD

### Introduction

Diffusers are available for flush mounting in the ceiling. Suitable angle frames are also provided for the modular panel construction. The units are available in three standard sizes for top entry complete with opposed blade dampers.

### Description

LFD laminar flow diffusers are constructed from 18 swg aluminium sheet, perforated face with approx. 50% perforation. The perforated front face is openable hinge type complete with key operated dampers from front.

### Sizes

Available in standard sizes of 600 x 600 mm, 900 x 600 mm & 1200 x 600 mm.

### Features

- Suitable for modular panel assemblies.
- Top entry with opposed blade dampers.
- Pivoting type face plate for damper operation from front.
- Easy maintenance and cleaning.

### Finishes

- Standard
- Epoxy Polyester Powder Coated off white/pure white.
  - Natural anodised.
- Other powder coating finishes available on request.



### Specification

Laminar flow diffusers shall be Ravistar model LFD constructed from aluminium sheet with perforated face plate (pivoting type), complete with key operated opposed blade damper.

### Ordering details

Type	Size	Neck Size
LFD	600 x 600	150 x 150

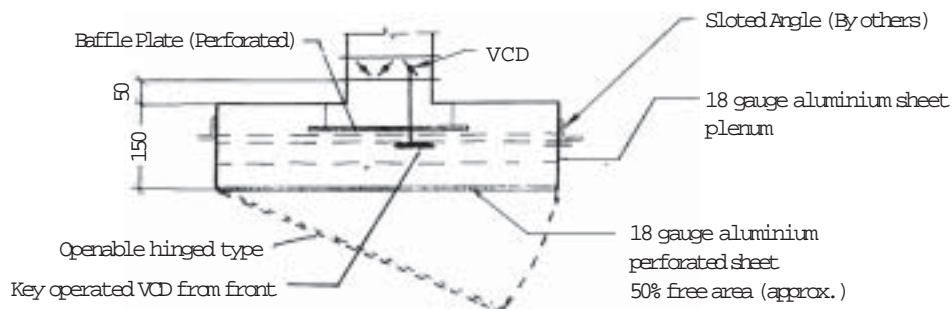

### Basis of data

- Laminar flow diffuser airstreams are characterised by the tendency to reduce in sectional area from the point of discharge, particularly with high cooling differentials. Although this produces a slight initial increase in the core velocity, friction between the airstream boundary and the static room air offsets this, the net result being to maintain a near constant air velocity at distances up to 2.5m from the face. This characteristic is reflected in the data presentation of tables 1 and 2 which give information on the face discharge velocity and the average airstream velocity over this distance. The discharge velocity is based on an average number of vane anemometer readings at the face plate, whilst the airstream velocity is derived from time averaged readings with a 15 probe array at distances of 1m and 2m from the face. In the case of the latter, data is given for cooling differentials of 3K, 5K and 10K.

- The temperature diffusion data presented in table 3 can be used to determine the approximate airstream temperature by adding the indicated temperature rise to the discharge air temperature.

- The acoustic data shown in table 5 is presented in terms of sound power based NR levels. To obtain the resulting NR<sub>1p</sub> level in the occupied zone, room absorption factors should be applied as appropriate to the installation conditions.

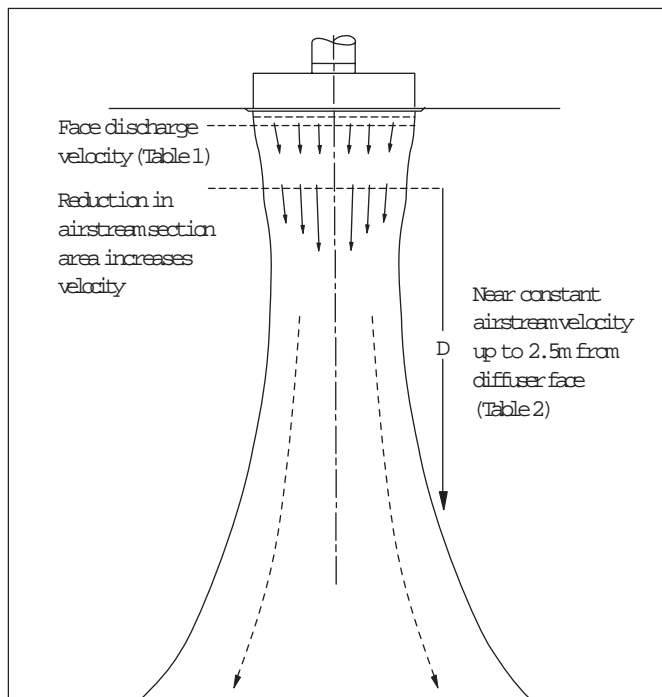

**Table 1. Average Face Air Velocity**

		Air Flow Rate (l/s)											
		20	30	40	50	60	80	100	120	140	160	180	200
Unit size		Average Face Air Velocity (m/s)											
600 x 600		0.05	0.1	0.13	0.17	0.21	0.3	0.37	-				
900 x 600		-	0.05	0.07	0.1	0.13	0.18	0.24	0.3	-			
1200 x 600			-	-	0.05	0.06	0.11	0.15	0.19	0.24	0.28	0.32	0.37

**Table 2. Average Airstream Velocity**

		Air Flow Rate (l/s)											
		20	30	40	50	60	80	100	120	140	160	180	200
Unit size	$\Delta T$	Average Airstream Velocity											
600	-3K	0.09	0.11	0.13	0.16	0.2	0.26	0.33	-				
	-5K	0.09	0.12	0.15	0.2	0.25	0.31	0.36	-				
	-10K	0.1	0.13	0.15	0.25	0.32	0.41	0.45	-				
900	-3K	0.07	0.09	0.11	0.12	0.14	0.16	0.22	0.25	-			
	-5K	0.07	0.1	0.13	0.17	0.2	0.23	0.29	0.32	-			
	-10K	0.08	0.11	0.15	0.2	0.24	0.28	0.36	0.4	-			
1200	-3K			-	0.05	0.07	0.09	0.1	0.14	0.22	0.26	0.29	0.31
	-5K			-	0.05	0.07	0.1	0.12	0.16	0.25	0.3	0.35	0.39
	-10K			-	0.05	0.1	0.17	0.23	0.3	0.38	0.42	0.45	0.47

**Table 3. Airstream Temperature**

		Air Flow Rate (l/s)												
		20	30	40	50	60	80	100	120	140	160	180	200	
Unit size	$\Delta T$	D	Airstream Temperature Rise ( $^{\circ}C$ )											
600 X 600	-3K	1 m	2.5	2.5	2.5	2.5	2.0	2.0	1.0	-				
		2 m	3.0	3.0	3.0	3.0	2.5	2.5	2.0	-				
	-5K	1 m	4.5	4.5	4.5	4.0	3.5	3.0	2.5	-				
		2 m	5.0	5.0	5.0	4.5	4.0	3.5	3.0	-				
	-10K	1 m	8.5	8.0	8.0	8.0	7.5	6.5	6.0	-				
		2 m	9.5	9.5	9.5	9.0	8.5	8.0	7.0	-				
900 X 600	-3K	1 m	3.0	3.0	3.0	3.0	2.5	2.5	2.0	1.5	-			
		2 m	3.0	3.0	3.0	3.0	3.0	2.5	2.5	2.0	-			
	-5K	1 m	5.0	4.5	4.5	4.5	4.0	3.5	3.0	2.5	-			
		2 m	5.0	5.0	5.0	5.0	4.5	4.5	4.0	3.5	-			
	-10K	1 m	10.0	9.5	9.5	9.0	8.5	8.0	7.0	5.5	-			
		2 m	10.0	10.0	9.5	9.5	9.0	8.5	8.0	7.0	-			
1200 X 600	-3K	1 m			-	3.0	3.0	3.0	2.5	2.5	2.0	2.0	1.5	1.0
		2 m			-	3.0	3.0	2.5	2.5	2.5	2.5	2.5	2.0	1.5
	-5K	1 m			-	4.5	4.5	4.5	4.0	4.0	3.5	3.0	2.5	2.0
		2 m			-	5.0	5.0	5.0	5.0	4.5	4.5	4.0	3.0	2.5
	-10K	1 m			-	10.0	10.0	10.0	9.5	9.0	8.0	7.5	6.5	5.5
		2 m			-	10.0	10.0	10.0	9.5	9.5	9.0	8.5	8.0	7.0

**Table 4. Diffuser Pressure Loss (open damper)**

		Air Flow Rate (l/s)											
		20	30	40	50	60	80	100	120	140	160	180	200
Unit size		Static Pressure Loss (Pa)											
600 x 600		1	1	1	2	2	4	5	-				
900 x 600		1	1	1	2	2	4	5	7	-			
1200 x 600				-	1	1	1	2	2	3	3	4	4

**Table 5. Acoustic Data (open damper)**

		Air Flow Rate (l/s)											
		20	30	40	50	60	80	100	120	140	160	180	200
Unit size		Noise Level (NRIw)											
600 x 600					< 20	20	24	28					
900 x 600						< 20	23	27	30				
1200 x 600												< 20	20

**Selection Example**

Diffuser selection criteria will be dependent on the application, but as a general guide most sedentary occupants would be tolerant of airstream velocities up to 0.25m/s if the air temperature is 1-2 $^{\circ}C$  below that in the room. In applications where there are concentrated heat sources or where the occupants are mostly transitory, this can generally be increased to 0.35 - 0.5m/s. As an example, consider the use of a 1200 x 600 diffuser in an operating theatre where the cooling differential is to be 5K with a supply air temperature of 17 $^{\circ}C$ .

Reference to table 2 shows that the maximum air flow rate to achieve an average airstream velocity of 0.25m/s would be 140ltrs/s. Airstream temperatures at distances of 1m and 2m from the diffuser face can be found from table 3; in this case, at 140ltrs/s, the supply air temperature will rise by 3.5 $^{\circ}C$  and 4.5 $^{\circ}C$  respectively, giving moving air temperatures of 20.5 $^{\circ}C$  and 21.5 $^{\circ}C$  at the two heights.

The diffuser noise level can be found from table 5, which, assuming a fully open damper, would be less than NRIw20 at 140l/s.

## Hi-Flo Jet Diffusers - Model RWH

### Introduction

Series RWH diffusers have been designed to handle high air flow rates and provide relatively long throws which makes them particularly suitable for conditioning of large spaces such as halls, auditoria, terminal buildings, warehouses and factories.

The diffusers are versatile in application by virtue of the novel "reversible and rotatable" core design which allows the air jet to be adjusted for both pattern and deflection. Units may be mounted individually or in banks in bulkhead arrangements or directly into stub ducts.

### Description

Units are constructed from aluminium spinnings supported on a studding and spacer assembly. The core may be rotated through 180° to expose either a straight or diffused core assembly. In addition, the diffuser spigot may be rotated within the mounting plate (if supplied) to enable a full 360° adjustment, by releasing the tension bolts.

### Types

**RWH** - Complete assembly includes diffuser core and mounting plate (wall or ceiling mounting).

**RWH-P** - Diffuser core only (suitable for mounting onto bulkheads or stub ducts thus eliminating the large mounting plate).



RWH-P



RWH (JET SETTING)



RWH (DIFFUSER SETTING)

### Features

- Simple and effective air diffusion for large spaces.
- Long throw characteristics.
- High air handling capacity.
- Easy to install and adjust.
- Reversible core to produce long throw jet or short throw diffuser patterns.
- Core rotatable through 360° for "eyeball" jet direction.
- Jet may be deflected off axis by up to 15°.
- Available in three sizes.
- Multiple outlet arrangements.

### Dimensions

Technical drawing of the RWH diffuser showing front, side, and detail views. The front view shows the diffuser core with dimensions A O/S and Ø B. The side view shows the diffuser core with a height of 15 and labels for 'RELEASE CLAMP SCREWS TO ROTATE DIFFUSER ASSEMBLY' and 'MOUNTING PLATE WITH CLAMP FIXING'. The detail view shows the diffuser core with labels for '1.5-15 PANEL THICKNESS', 'CLAMP FIXING TO PANEL', 'Ø b PANEL CUTOUT', 'CEILING OR WALL PANEL', and 'Ø C O/S SPIGOT'.

UNIT SIZE	A O/S	Ø B	Ø C O/S
250	349	285	248
315	399	350	313
380	499	415	378

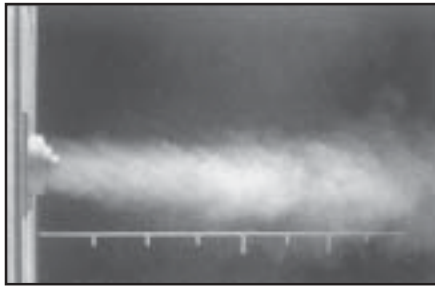

Jetsetting 0°

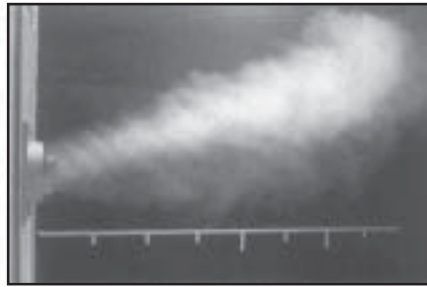

Jetsetting 15°

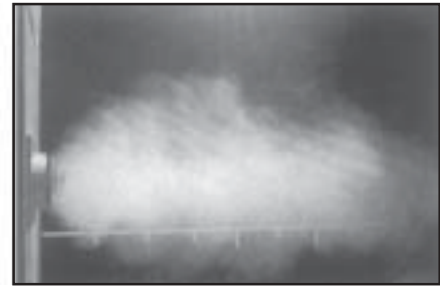

Diffuser setting

Performance Data

All data is for the diffuser set for 0° deflection and operating under isothermal conditions in either "jet" or "diffuser" pattern. Correction factors for 15° deflection are given below. NR Level = Peak level on NR curves based on SWL re 10<sup>-12</sup>W less 8 dB room absorption.

Throw = Forward distance to the point where the jet velocity has retarded to a terminal velocity of 0.5 m/s.  
Ps = Static pressure loss (Pa).

CORRECTIONS FOR 15° HI-FLO SETTING	JET	DIFFUSER
NR LEVEL ADDITION	+11dB	+4 dB
PRESSURE LOSS MULTIPLIER	1.25	1.25

CORRECTION FACTORS FOR TERMINAL VELOCITIES OTHER THAN 0.5 m/s						
Vt (m/s)	0.2	0.3	0.4	0.5	1.0	1.5
Factor	2.5	1.7	1.25	1.0	0.5	0.3

SIZE	PATTERN	PARAMETER	AIR FLOW RATE PER DIFFUSER (l/s)														
			100	125	150	200	250	300	400	500	600	800	1000	1200			
RWH-250	JET	NR LEVEL	-	17	22	30	36	41	48								
		THROW (m)	4.0	5.1	6.0	7.2	10.0	12.0	16.5								
		Ps (Pa)	6	10	14	21	31	43	80								
	DIFFUSER	NR LEVEL	-	-	14	24	32	38	49								
		THROW (m)	2.0	2.6	3.0	3.6	5.0	6.0	8.3								
		Ps (Pa)	6	10	14	21	31	43	80								
RWH-315	JET	NR LEVEL					19	24	33	39	44	53					
		THROW (m)			5.0	6.8	8.5	9.8	13.0	16.0	20.0	26.0					
		Ps (Pa)			4	8	13	18	30	45	60	105					
	DIFFUSER	NR LEVEL	-	-	-			20	31	39	45	57					
		THROW (m)			2.5	3.4	4.3	4.9	6.5	8.0	10.0	13.0					
		Ps (Pa)			4	8	13	18	30	45	60	105					
RWH-380	JET	NR LEVEL				-	-	-	21	28	33	41	48	53			
		THROW (m)				5.4	6.8	8.0	10.5	14.0	16.4	22.0	28.0	35.0			
		Ps (Pa)				3	5	7	12	20	30	50	70	100			
	DIFFUSER	NR LEVEL				-	-	-	14	23	30	41	50	57			
		THROW (m)				2.7	3.4	4.0	5.3	7.0	8.2	11.0	14.0	17.5			
		Ps (Pa)				3	5	7	12	20	30	50	70	100			

CORRECTIONS FOR MULTIPLE UNITS				
NO. UNITS	1	2	3	4
NR LEVEL ADDITION	0	+3	+5	+6
THROW FACTOR	1.0	1.37	1.86	2.06

When diffusers are mounted on a common plate/plenum the noise level and throw will increase by the factor above.

DATA IS BASED ON ISOTHERMAL SUPPLY AIR CONDITIONS To estimate maximum VERTICAL projection under heating conditions multiply 'jet' throw data above by relevant factor below

SIZE	HEATING DIFFERENTIAL		
	5°C	10°C	20°C
RWH-250	1.20	0.85	0.60
RWH-315	1.10	0.75	0.55
RWH-380	1.00	0.65	0.45

NOTE - DO NOT CORRECT THROW DATA FOR OTHER TERMINAL VELOCITIES

To estimate vertical projection under cooling conditions multiply throw (to relevant terminal velocity) by factors as follows:- 10°C cooling x 1.15, 5°C cooling x 1.10

Spectrum correction data to obtain SWL by octaves						
Frequency (Hz)	125	250	500	1K	2K	4K
Diffuser / 0°	-1	+1	+3	+8	+7	0
Diffuser / 15°	0	+2	+4	+8	+7	+2
Jet / 0°	-3	-1	+3	+8	+6	+5
Jet / 15°	+1	+3	+4	+7	+6	+1

### Finish

Standard a) Epoxy Polyester Powder Coated off white/pure white.  
 b) Natural anodised.  
 Other powder coating finishes available on request.

### Installation

**Type RWH** - Units should be bolted through holes provided on the mounting plate onto plenum chambers, ductwork or architectural bulkheads.

**Type RWH-P** - Units may be fixed directly into or onto circular duct connections by screwing through spigot. Special plenum and ducting assemblies are available to suit individual project requirements.

Air distribution to each diffuser should be as even as possible in order to attain design performance. Ravistar are able to provide a complete design and manufacturing service for standard and special plenum arrangements to ensure this.

### Duct Mounted

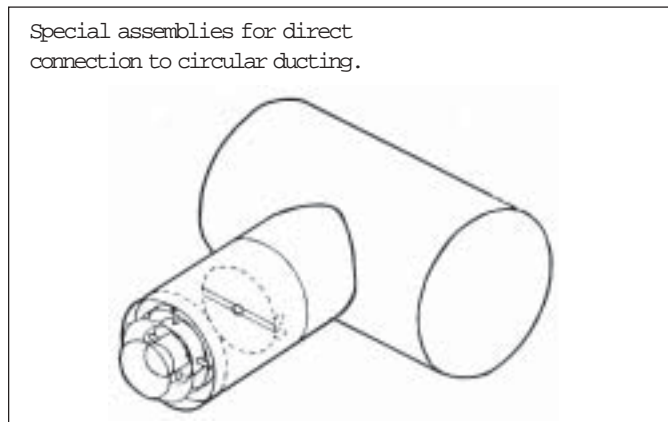

**Type RWH-P less mounting plate.**

### Plenums (single and modular)

Full details of standard PB/RWH plenums are available from Ravistar.

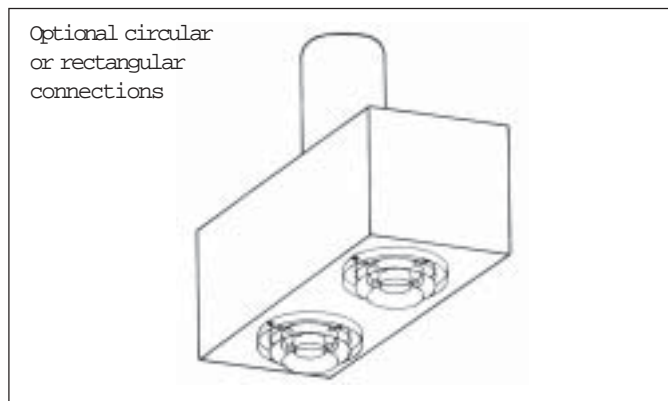

### Plenums (special)

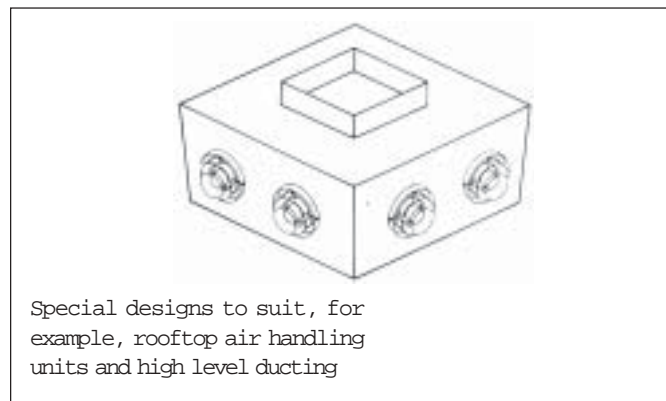

### Specification

High capacity "jet or nozzle" diffusers shall be Ravistar type RWH constructed from Aluminium spinings. All units shall be capable of providing "eyeball" type air pattern adjustment and must incorporate a reversible core assembly to allow long and short throws to be produced.

### Ordering

When ordering please state type, size, finish and number off required.

Type	Size
RWH	250

State plenum requirements separately.

### Legend

Type : RWH - Complete assembly with mounting plate  
 RWH-P - Core assembly

Size : 250, 315, 380

## Large Format Circular Diffusers - Model WR

### Introduction

The WR Series is suitable for ceiling or exposed ductwork mounting and includes a rotating central core adjustment feature to provide settings for projection heating and spot cooling or conventional horizontal diffusion. Manufactured from aluminium spinnings, the series is available with a range of dampers and equalising grids for effective control of air distribution.

### Description

#### Manufacture

WR circular diffusers are manufactured from aluminium spinnings and components.

### Dimensions

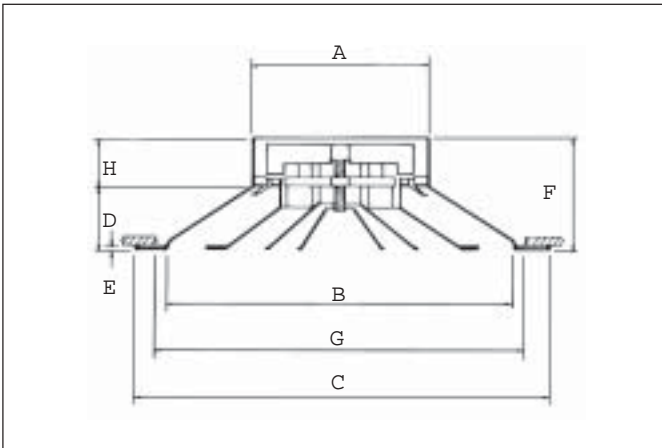

Size	12	18	24
A	305	457	610
B	610	914	1080
C	680	1040	1170
D	95	146	173
E	6	24	18
F	180	246	273
G	640	950	1100
H	85	100	100

### Finish

Standard a) Epoxy Polyester Powder Coated off white/pure white.  
 b) Natural anodised.  
 Other powder coating finishes available on request.



An attractive, high performance adjustable circular diffuser in a range of sizes, suitable for all heating, cooling and ventilation systems.

### Features

- High air handling capacity
- Easily removable central core assembly
- Simple installation
- Maintenance free, quality product
- Core adjustment feature
- Range of accessories
- Suitable for supply and exhaust

### Ordering

When ordering state quantity, type, size and finish.

Type	Size
W R	12

Specify quantity and finish separately.

### Legend

Type : W R

Size : See neck size options and dimensions on page 23.

### Installation

Remove core from bayonet fixing and place diffuser frame into opening.

Screw fix through diffuser stack into duct. Replace core ensuring the bayonet fixing is secure.

### Performance

**Radius of diffusion :** The minimum and maximum throw covered by one diffuser which results in an average air velocity in the occupied zone of 0.25 m/s and 0.10 m/s respectively (based on 3.0m mounting height and 10°C cooling).

**NC level :** Peak level on Noise Criteria curves based on sound power level re 10<sup>-12</sup>W less 8dB room absorption.

**Pressure loss :** Static pressure loss at the supply duct (Pa).

**Exhaust :**

$$P_s (\text{exhaust}) = P_s (\text{supply}) \times 1.2$$

$$NC (\text{exhaust}) = NC (\text{supply}) + 3 \text{ dB}$$

**Cone settings**

Setting B : Flush for general applications producing horizontal diffusion (performance as table). Setting A : Projection setting - multiply tabulated PS X 1.70, add 2 dB to NC values.

Setting C : Exposed duct setting - multiply tabulated PS X 0.80, subtract 2 dB from NC values.

**Horizontal Diffusion : Supply**

Neck diameter	Parameter	Neck velocity (m/s)					
		4	5	6	7	8	10
305	Q (l/s)	292	366	438	511	585	731
	Ps (Pa)	16	25	37	50	66	102
	Rad. (m)	1.5-3	2.1-3.9	2.1-4.5	2.7-5.1	3-6	3.9-7.5
	NC (dB)	26	34	40	45	49	56
457	Q (l/s)	656	820	984	1148	1312	1641
	Ps (Pa)	10	16	23	32	42	66
	Rad. (m)	2.4-4.5	3-6	3.6-7	4.2-8.1	4.8-7.3	6-12
	NC (dB)	28	35	41	46	50	57
610	Q (l/s)	1168	1460	1750	2045	2340	2920
	Ps (Pa)	13	21	30	41	56	84
	Rad. (m)	5-10	5.5-11	6-12	6.5-13	8-16	10-20
	NC (dB)	35	41	47	51	55	62

Projection is based on isothermal supply conditions with a terminal velocity of 0.5m/s. Correct for heating, cooling and other V<sub>t</sub>.

Heating Δt (°C)	5	10	15	20	25	30
Projection Factor	0.98	0.95	0.85	0.75	0.62	0.50
Projection Factor for cooling Δt = 10°C - 1.15						
Terminal Velocity V <sub>t</sub> m/s	0.75	0.50	0.40	0.30		
Correction Factor	0.80	1.0	1.11	1.30		

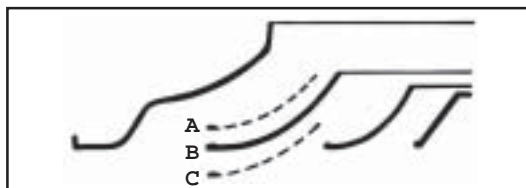

**Vertical Projection Data - Cone setting A**

Projection : Use graph below. For required throw corrected for temperature differential select suitable size and neck velocity.

Noise generation and Pressure loss : Use the table for horizontal diffusion corrected for cone setting.

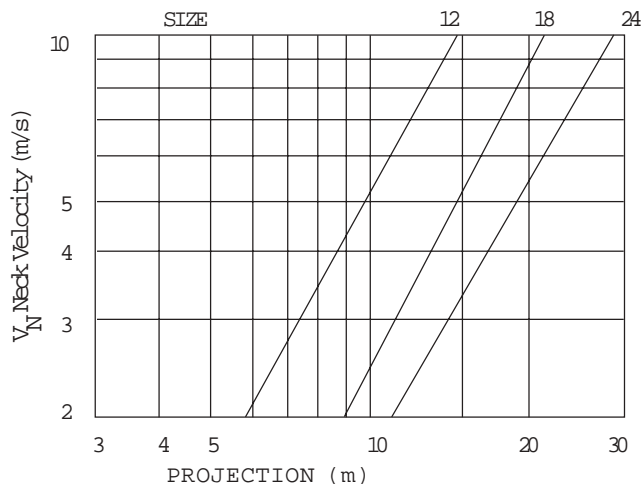

## Small Format Circular Diffusers - Model MC

### Introduction

The MC diffuser range has been designed for both supply and exhaust applications requiring compact circular diffusers; unlike conventional high aspiration diffusers the MC has a small overall to neck size ratio. The diffusers are adjustable to produce horizontal or vertical air patterns.

### Description

#### Manufacture

Constructed from aluminium spinnings retained on aluminium spider braces.

#### Sizes

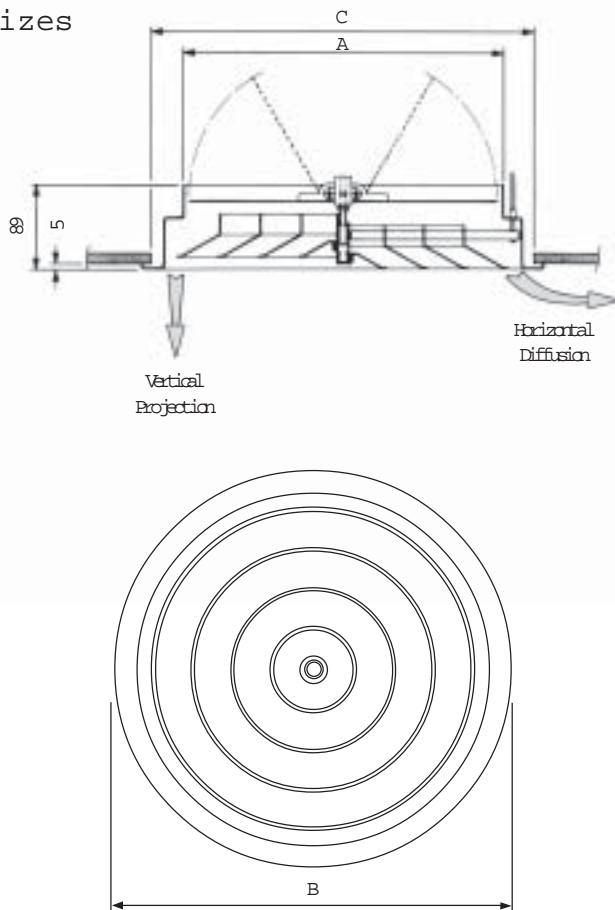

Diffuser & Duct Size	Overall Diameter	Ceiling Opening
A Ø	B Ø	C Ø
200	305	280
300	381	356

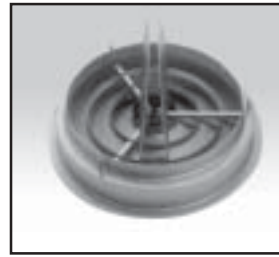

### Features

- Compact frame design.
- Robust construction.
- Adjustable for vertical or horizontal air patterns.

### Finish

Standard a) Epoxy Polyester Powder Coated off white/ pure white.

b) Natural anodised.

Other powder coating finishes available on request.

### Accessories

Controls :

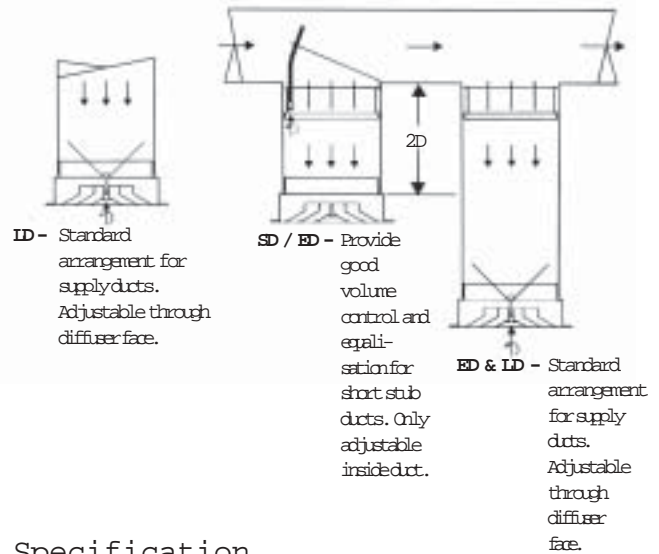

### Specification

Small format diffusers shall be Ravistar type MC constructed from aluminium spinnings. Diffusers shall be adjustable to produce vertical or horizontal diffusion patterns.

### Ordering

Type	Size	Control
MC	200 Ø	LD

### Legend

Type - MC supply or exhaust

Control - See options above (order duct mounted controls separately).

Size - 200, 300 dia.

## Installation

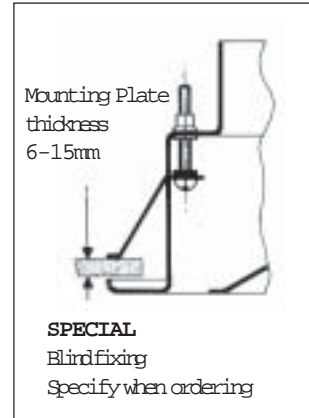
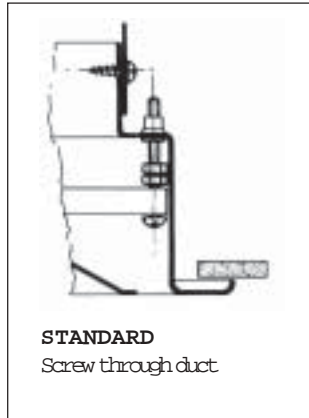

**Note :** Diffuser core may be removed to improve access for installation.

## Performance

### Supply Horizontal Diffusion

Radius of diffusion.

Minimum - space covered by one diffuser which results in a mean room air movement of 0.25 m/s. Maximum - space covered by one diffuser which results in a mean room air movement of 0.10 m/s.

Size	NECK VELOCITY (m/s)	1	2	3	4	5
200	Flow (l/s) 3l	63	94	126	157	
	Radius of Diffusion					
	- Min (m)	0.5	0.9	1.5	2	2.5
	- Max (m)	1	1.8	3	4	5
	NC Level	-	-	21	31	40
	Pressure Loss (Pa)	2	9	21	37	58
300	Flow (l/s) 7l	141	212	282	353	
	Radius of Diffusion					
	- Min (m)	0.7	1.4	2.1	2.8	4
	- Max (m)	1.5	2.8	4.2	5.6	8
	NC Level	-	18	29	39	46
	Pressure Loss (Pa)	2	9	21	37	58

### Supply Vertical Projection

Projection - downward throw to a terminal velocity

$V_t = 0.5 \text{ m/s}$

Size	NECK VELOCITY (m/s)	1	2	3	4	5
200	Flow (l/s)	31	63	94	126	157
	Projection (m)	1.3	2.1	3.0	4.3	5.2
	NC Level	-	19	31	39	46
	Pressure Loss (Pa)	4	17	38	65	105
300	Flow (l/s)	71	141	212	282	353
	Projection (m)	2.0	3.1	4.6	6.3	7.8
	NC Level	-	22	34	43	49
	Pressure Loss (Pa)	5	20	48	80	125

## Exhaust

Size	NECK VELOCITY (m/s)	1	2	3	4	5
200	Flow (l/s)	31	63	94	126	157
	NC Level	-	-	23	33	41
	Pressure Loss (Pa)	4	15	31	51	76
300	Flow (l/s)	71	141	212	282	353
	NC Level	-	17	32	42	50
	Pressure Loss (Pa)	6	23	49	80	120

### Basis of data

NC Level : Equal to the peak sound power level on an NC curve less 8dB for normal room absorption.

Pressure Loss : Static pressure loss of the diffuser (Pa).

Throw : Radius of diffusion and projection - see individual tables.

## Spot Diffusers / Jet Nozzles - Model RSD

### Introduction

Spot Diffusers / Jet Nozzles are used for preference where the supply air from the diffuser has to travel a large distance to the occupied zone. This is the case in large areas (large halls, warehouses, shopping malls, assembly rooms etc.), particularly where the supply of air via ceiling diffusers is not possible or not practical. These diffusers / nozzles can be installed in the ceilings or side walls.

The supply air direction can be changed by the swivel movement of the diffuser / nozzle within a range  $\pm 40^\circ$  in both the planes.

### Description

Units are constructed from aluminium spinnings supported on the flange assembly which can be fixed to the duct collar or suitable frame.

### Features

- Simple and effective air diffusion for large spaces.
- Ideal for large air volumes & long throws.
- Nozzle rotatable  $\pm 40^\circ$  for "Eyeball" jet direction.
- Available in three sizes

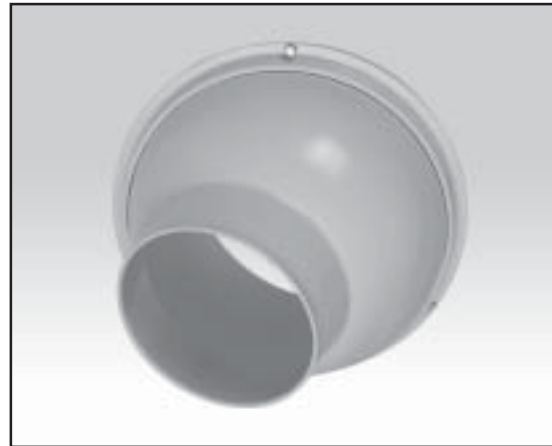

### Finish

Standard a) Epoxy Polyester Powder Coated off white/pure white.

b) Natural anodised.

Other powder coating finishes available on request.

### Dimensions

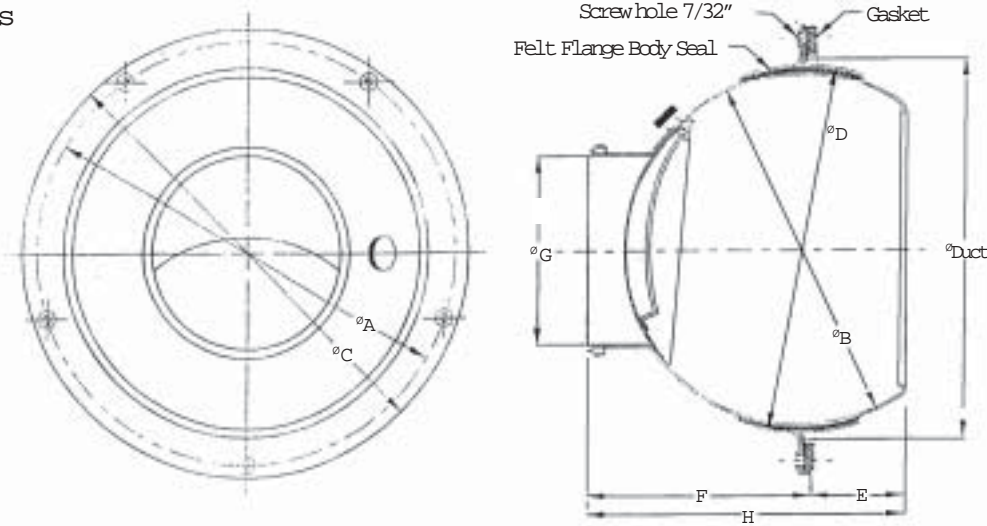

Size	A	B	C	D	E	F	G	H	Duct Opening	Max. Rot. Angle
8	230	200	250	203	45	120	100	165	208	42°
12	340	304	362	314	62	200	165	262	318	39°
16	450	410	470	420	92	247	225	340	425	40°

Dimensions in mm

### Specification

High capacity diffuser / nozzle shall be Ravistar type RSD constructed from aluminium spinings. The unit shall be capable of providing "Eyeball" type air pattern adjustment.

### Legend

Sizes - 8, 12, 16

### Ordering

When ordering please state type, size, finish and number off required.

Type	Size
RSD	8

### Installation

Install the diffuser on the duct flange / suitable frame with screws through the holes provided in the diffuser flange.

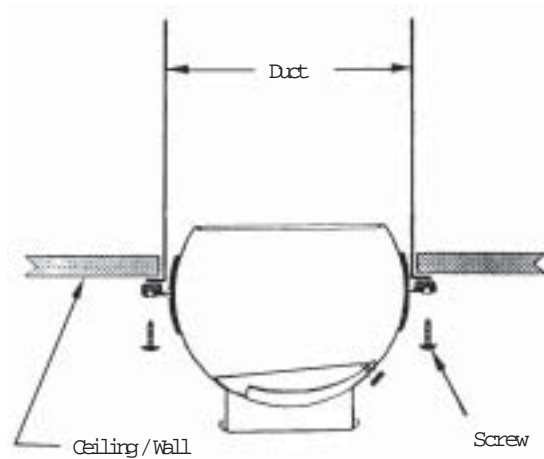

### Performance

Size	Approx. Nozzle Vel. m/s		2.54	5.08	7.62	10.16	12.7	15.24	17.78	20.32
	Terminal Velocity m/s		0.25,0.50,0.75,1.0	0.25,0.50,0.75,1.0	0.25,0.50,0.75,1.0	0.25,0.50,0.75,1.0	0.25,0.50,0.75,1.0	0.25,0.50,0.75,1.0	0.25,0.50,0.75,1.0	0.25,0.50,0.75,1.0
8	Nozzle area	Flow Lt/Sec	21	42	61	80	103	122	141	160
	sq. ft.	sp(mm.wg)	0.40	1.52	4.32	6.86	9.65	16.25	23.36	30.48
		NC	-	<20	<20	22	27	33	35	39
		Throw(ft)	8, 4, 2.15, 1.23	12, 6, 3.6, 1.8	19, 9, 4.8, 2.7	26, 11.8, 6, 3.35	32, 15.8, 8.2, 3.9	38, 19, 9.1, 5.2	45.7, 22, 17, 5.8	49, 24, 11.6, 6
12	Nozzle area	Flow Lt/Sec	54	108	165	217	273	325	382	434
	sq. ft.	sp(mm.wg)	0.30	1.59	4.58	5.50	10.9	15.25	23.36	30.48
		NC	-	<20	<20	23	28	32	36	40
		Throw(ft)	10, 5.2, 2.8, 1.8	20, 10, 5, 2	30, 15, 8, 4	42, 20, 10, 5.2	49, 25, 17.8, 6.7	57, 30, 15, 7.5	67, 34, 17, 9	76, 39.6, 21.4, 10.3
16	Nozzle area	Flow Lt/Sec	106	212	320	424	528	637	740	850
	sq. ft.	sp(mm.wg)	0.30	1.52	3.04	5.33	10.41	15.75	22.86	30.48
		NC	-	20	21	26	29	37	40	44
		Throw(ft)	14, 7.6, 3.6, 2.1	27.4, 14.3, 7.3, 3.6	42, 20, 11, 5.5	53, 29, 15, 7.5	68.5, 34, 16.7, 8.5	76, 41.7, 20, 10.6	84, 49, 24, 12.8	106, 53, 29, 14.3

Dashed line in sp box indicates static pressure is less than 0.25 mm in w.g.

Dashed line in nc box indicates noise is less than 20.

NC level is based in 10dB room attenuation (pwl re:10<sup>-12</sup> w) with one diffuser operating.

## Swirl Diffusers - Model WTF

### Introduction

Ravistar range of fixed blade swirl diffusers presents an attractive and aerodynamically efficient alternative to conventional circular or square ceiling air terminals.

The diffusers are designed to produce a horizontal, radial air pattern with a turbulent, high induction jet characteristic and are ideally suited for applications with high heating or cooling differentials.

Manufactured from press formed aluminium blades, the units are available in two neck / nominal sizes 200, 315mm with out to out size of 595 x 595mm suitable for tile replacement. The face plates are manufactured from 16 swg aluminium sheet, powder coated to give a durable and clean surface.



### Controls

Side entry plenums are optionally available with spigot mounted quadrant.

### Dimensions

### Finishes

Standard a) Epoxy Polyester Powder Coated off white/pure white.

b) Natural anodised.

Other powder coating finishes available on request.

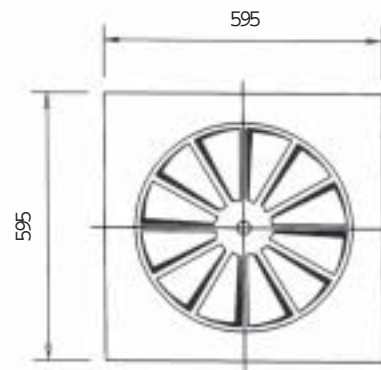
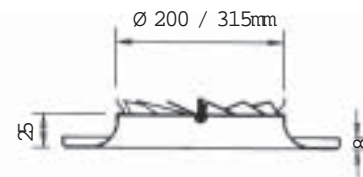

WTF Diffuser

### Ordering Details

When ordering diffusers state type, neck size, plate size and required finish. Damper and plenum requirements should be specified separately.

Type	Neck / Nominal size
WTF	200, 315

## Performance

### Basis of data

Jet throw data is expressed in terms of maximum and minimum throws based on terminal velocities ( $V_t$ ) of 0.2m/s and 0.5m/s. These correspond to average air velocities ( $V_a$ ) in the occupied zone of 0.1 m/s and 0.2m/s respectively and are applicable to room heights ranging from 2.7 - 3.0m. Data is based on a 10°C cooling differential. For isothermal or 10°C heating conditions apply a factor of 1.15 to the throws.

Acoustic data is for a duct mounted diffuser in terms of sound pressure based NR levels and assumes a room absorption factor of 8dB. A correction of NR2 should be added for diffusers fitted with side entry plenums.

Additional octave band data is available upon request.

Pressure loss data is shown in terms of static pressure loss (Pa) measured at the supply duct to the diffuser.

For diffusers installed in plenums, increase the pressure by a factor of 1.25.

### Jet throw, pressure loss and acoustic data

Nominal size	Parameter	Air flow rate (l/s)													
		10	20	30	40	50	60	70	80	90	100	120	140	160	
200	Throw (m)	Min		0.4	0.6	0.9	1.3	1.5	1.8						
		Max		1.4	2.0	2.5	3.0	3.3	3.6						
	Ps (Pa)		4	9	15	22	30	40							
	NR		-	-	20	27	32	36							
315	Throw (m)	Min				0.8	1.0	1.2	1.3	1.4	1.6	1.9	2.2	2.4	
		Max					2.0	2.3	2.5	2.8	2.9	3.2	3.4	3.5	3.6
	Ps (Pa)					5	7	9	11	14	17	25	33	41	
	NR					-	-	-	-	22	25	30	35	38	

Acoustic and pressure loss data shown in the above table is also valid for extract applications.

### Selection Example

WIF 315 diffuser supplying an air flow rate of 120 ltrs/s : (without damper)

Ducted diffuser :

Jet throw range, 1.9-3.4m

Static pressure loss, 25 Pa

Noise level, NR 30

## Adjustable Vane Diffusers - Model ACD

### Introduction

ACD diffusers are ideally suited to commercial and industrial projects requiring relatively low cost but versatile air outlets. Available with 1, 2, 3 or 4 way patterns with individually adjustable vanes the diffusers can be supplied in all sizes to suit ceiling or duct integration requirements.

As the air pattern is easily adjustable from the face it is recommended that ACD diffusers are not located in low or easily accessible ceiling locations.

### Description

#### Manufacture

Diffusers are constructed from aluminium alloy extrusions with cleated or welded frames and pretensioned vanes.

### Types

ACDH - vanes parallel to width dimension

ACDV - vanes parallel to height dimension

ACDH1 or ACDV1 - 1 way pattern

ACDH2 or ACDV2 - 2 way pattern

ACDH3 or ACDV3 - 3 way pattern

ACDH4 or ACDV4 - 4 way pattern

### Sizes

**Standard Sizes** - Minimum 250x250mm  
- Maximum 600x600mm

**Special Sizes** (ACD1 & ACD2 only)  
- Minimum 150x100  
- Maximum 1500x1500

### Dimensions

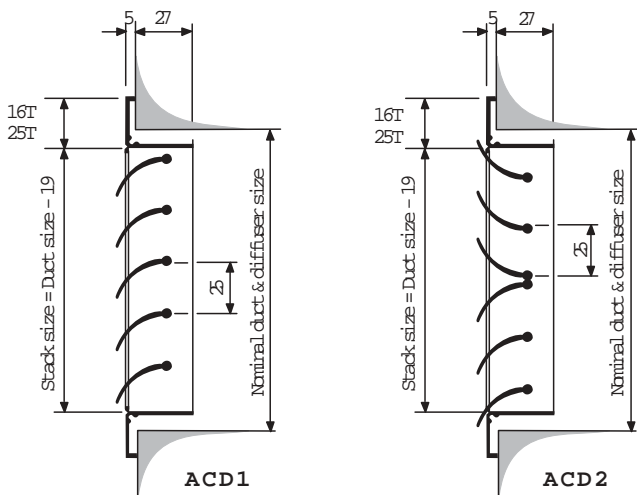

### Finish

Standard a) Epoxy Polyester Powder Coated off white/pure white.

b) Natural anodised.

Other powder coating finishes available on request.

### Specification

Adjustable vane diffusers shall be Ravistar type ACD with pretensioned vanes retained within a welded or cleated frame.

### Features

- 1, 2, 3 & 4 way patterns
- Variable size range
- Adjustable air patterns
- Vertical or Horizontal diffusers

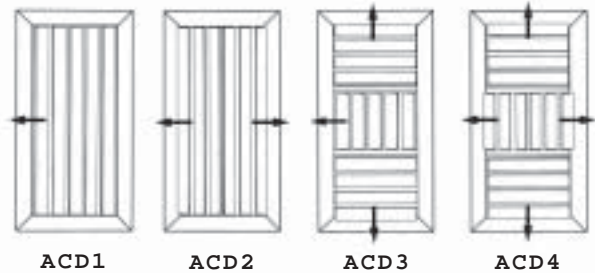

### Installation

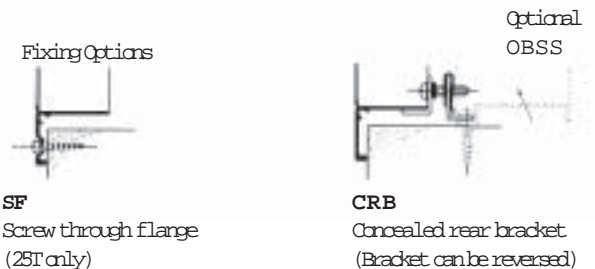

### Ordering

Width	Height				
Type	W	H	Border	Fixing	Control
ACDH2	300	300	25T	SF	OBSS

### Legend

- Type : See options on page 30
- Control : OBSS must be ordered separately
- Width : Nominal duct width (mm)
- Height : Nominal duct height (mm)
- Blade : Horizontal 'H' or Vertical 'V' (applies to ACD1 and ACD2)

## Performance

Curved Vane Diffusers  
Types : ACD1 ACD2 ACD3 ACD4  
FREE JET DATA  
(see note below)

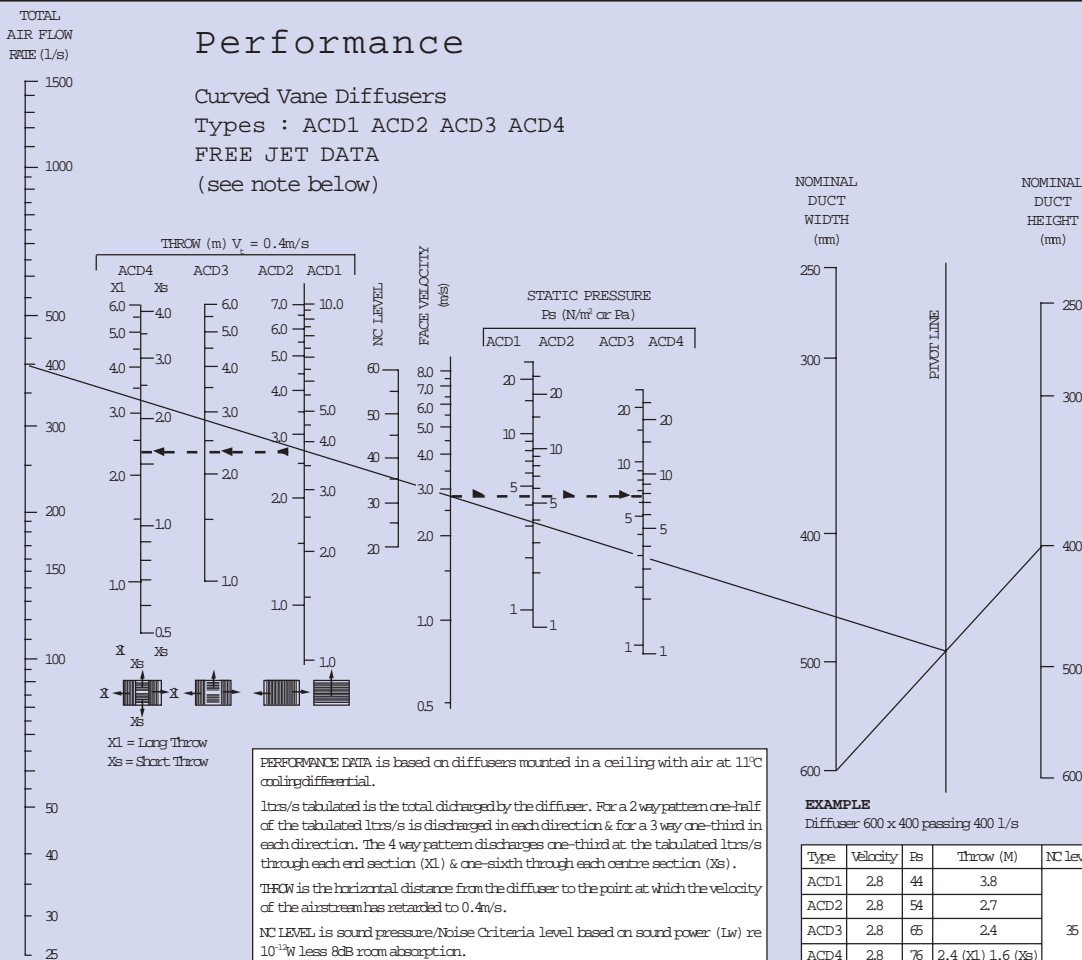

FREE JET (VANES AS BELOW)  
PERFORMANCE AS NOMOGRAM

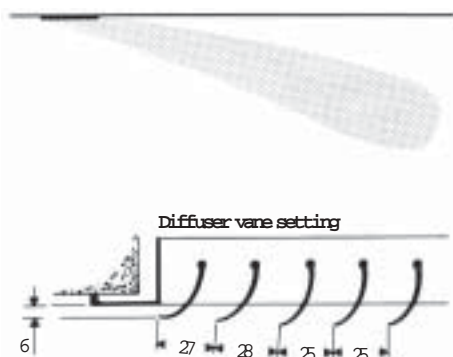

CEILING JET (VANES AS BELOW)

PERFORMANCE THROW = T<sub>NOM</sub> X 2.5  
PRESSURE LOSS = Ps<sub>NOM</sub> x 3  
NOISE LEVEL NC<sub>NOM</sub> + 11 dB

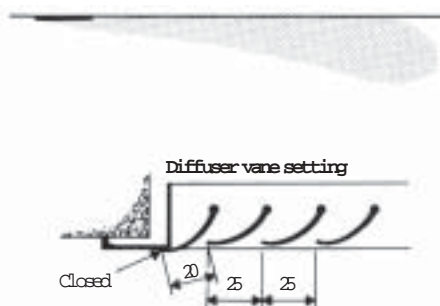

## Exhaust Valves - Model VB

### Introduction

A range of high quality valves for exhaust applications for commercial and industrial projects. These valves are best applied to air distribution systems handling relatively low air flow rates within small circular ductwork. The valves provide high initial resistance with wide throttling capability which is necessary to offset the relatively high system resistances.

### Type

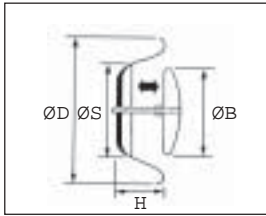

**VB - Exhaust valve with spindle lock nut**

	125	200
<b>D</b>	161mm	248mm
<b>S</b>	97mm	156mm
<b>B</b>	100mm	157mm
<b>H</b>	49mm	64mm

### Finish

Standard : Epoxy Polyester Powder Coated off white/pure white.

Other powder coating finishes available on request.

### Subframe Detail

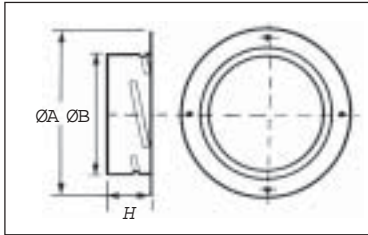

NOMINAL SIZE		
	125	200
<b>A</b>	125mm	200mm
<b>B</b>	155mm	236mm
<b>H</b>	29mm	33mm

### Performance

VB Valve	Size (mm)	Flow Rate (l/s)	10	20	30	40	50	60	80	100	120	140
	125	Ps (Pa)	8	30	70	130	170					
	dBA	-	-	24	32	37						
200	Ps (Pa)				7	13	19	32	55	70	90	
	dBA				-	-	-	27	33	37	41	



### Description

All valves are constructed from steel spinnings protected by white powder coated finish. Flanges are fitted with sealing gaskets and all units are supplied as standard with plated steel mounting subframes.

### Installation

All units are supplied with a steel mounting subframe which should be fixed to the prepared opening.

- Cut aperture to suit subframe size shown opposite.
- Screw subframe into aperture.
- Offer valve body into subframe and rotate into bayonet fixing.

### Ordering

When ordering, state quantity, type and size.

Type	Size
VB	125 Ø

Specify quantity and special finish requirements separately.

### Legend

Type : VB

Size : 125, 200mm

### Basis of Data

The performance figures given above are based on a fully open valve.

**Ps** = Static pressure loss (Pa)

**dBA** = 'A' weighted sound pressure level based on 8dB room absorption.

- 
- Specifications and data are subject to change without prior notice due to continuous product development.
  - Normal tolerances shall be applicable.



**Ravistar India Pvt. Ltd.**

Office & Works : D-99, Sector-2, Noida-201301 (U.P.), India  
Tel. : 95 (120) 2531869, 2531878, 2537624 Fax : 95 (120) 2543431  
E-mail : [ravistar@vsnl.net](mailto:ravistar@vsnl.net) Visit us at : [www.ravistar.com](http://www.ravistar.com)